



Katalog montažnih betonskih elementov
Catalog of assembly concrete elements









Vsebina

Content

O nas <i>About us</i>	1-6
Temeljne čaše <i>Foundation cups</i>	7-8
Stebri <i>Columns</i>	9-16
Medetažni nosilci <i>Floor beams</i>	17-20
Votle plošče <i>Hollow-core slabs</i>	21-24
TT plošče <i>Double TT slabs</i>	25-26
Žerjavne proge <i>Crane girders</i>	27-28
Glavni nosilci <i>Main beams</i>	29-34
Gredice <i>Purlins</i>	35-40
Večnamenske pravokotne grede <i>Multipurpose rectangular beams</i>	41-42
Fasadni paneli <i>Facade panels</i>	43-48
Nakladalne ploščadi <i>Loading docks</i>	49-50
Sistem za gradnjo stavb <i>System for residential building</i>	51-56
Stopnice <i>Stairs</i>	57-60
Ref. objekti <i>Ref. objects</i>	61-62

O nas

Podjetje, ki je specializirano za gradnjo večjih poslovnih prostorov in skladiščnih hal po sistemu montažnih prefabriciranih visokokakovostnih AB elementov, z upoštevanjem kvalitete, varovanja okolja in racionalizacije investicije.

Smo relativno mlado podjetje, ki je bilo ustanovljeno leta 2017 s strani srbskega podjetja PUT inženjering d.o.o., ki je na trgu prisoten že skoraj trideset let in je eden glavnih ponudnikov prefabriciranih AB elementov na Balkanu. Z nakupom, prenovo in posodobitvijo obstoječih proizvodnih obratov ter poslovnih prostorov v Leskovcu pri Krškem, se je proizvodnja montažnih betonskih elementov začela. Poleg obrata v Krškem, sta še dva obrata v Srbiji, matični v Nišu ter drugi v Novi Pazovi pri Beogradu. Skupna kvadratura proizvodnih prostorov presega 37.000 m². Z dobro komunikacijo in sodelovanjem se tako znanja in izkušnje prelivajo tudi na Mobeco d.o.o., kar je vsekakor dodana vrednost podjetja.

Pomembni mejniki

2017 – ustanovitev podjetja in nakup proizvodnih in upravnih prostorov

2018 – pridobitev certifikatov o skladnosti procesov ISO 9001, 14001 in 45001

2018 – CE znak

2020 – linija za proizvodnjo votlih plošč





- ABOUT US
- FOUNDATION CUPS
- COLUMNS
- FLOOR BEAMS
- HOLLOW-CORE SLABS
- DOUBLE-TT SLABS
- CRANE GIRDERS
- MAIN BEAMS
- PURLINS
- MULTIPURPOSE RECTANGULAR BEAMS
- FACADE PANELS
- LOADING DOCKS
- SYSTEM FOR RESIDENTIAL BUILDING
- STAIRS
- REF. OBJECTS

About us

The company is specialized for prefabricated structures construction of large business premises and warehouses in accordance with the system of prefabricated high-quality RC elements, with respect to quality, environmental protection and rationalization of investment.

We are relatively young company, founded in 2017 by the Serbian company PUT inženjering d.o.o., which has been presented on the market for almost thirty years and is one of the main providers of prefabricated RC elements in Balkan region. With the purchase, renovation and modernization of the existing production facilities and business premises in Leskovec pri Krškem, Slovenia the production of the precast concrete elements began. In addition to the Krško plant, there are two others plants in Serbia, the parent plan in Niš and another in Nova Pazova near Belgrade. The total floor area of the production premises exceeds 37.000 m². Good communication and cooperation are definitely an added value of the company.

Important milestones

- 2017** – company foundation and purchase of production and administrative premises
- 2018** – ISO 9001, 14001 and 45001 certifications
- 2018** – CE mark
- 2020** – instalation of a line fort he production of hollow core slabs



Zakaj izbrati nas

Gradimo zaupanje

NAJBOLJŠA STROKOVNA PODPORA

Naša znanja in izkušnje so vam ves čas na voljo. Tesno sodelovanje je ključnega pomena že v fazi projektiranja. Konstrukcijo vašega objekta prilagodimo tako, da dobimo optimalni izkoristek vloženi sredstev. Nudimo vam strokovno podporo, od zasnove do izvedbe projekta.

BEST PROFESSIONAL SUPPORT

All our knowledge and experience is at your disposal at all times. A close collaboration is crucial all the way from the design phase. Optimal solutions pay off until the end of construction; a good professional support is invaluable.





Why choose us

We build trust

PRILAGODLJIVOST

Sistem montažnih betonskih konstrukcij je sestavljen iz tipskih proizvodov, iz katerih lahko sestavljamo konstrukcijo, ki popolnoma ustreza vašim zahtevam. Razumemo vaše potrebe in jih tudi poskušamo predvideti. Naša proizvodnja je dovolj prilagodljiva, da lahko zadovoljimo tudi najbolj specifične zahteve. Za vaše zadovoljstvo smo vedno pripravljeni iti korak dlje.

ZANESLJIVOST

Vsak objekt ima svoje posebnosti in vsak objekt je popolnoma nov izziv. Zato redno preverjamo kakovost in ves čas iščemo možnosti za izboljšanje. Dogovorjene standarde vedno dosegamo, še raje pa jih presežemo, ker je odlično narejen objekt naše največje zadovoljstvo in hkrati najboljša reklama.

KOREKTNOST

Naše podjetje sestavlja ekipa ljudi, ki se neprestano izobražuje, izmenjuje izkušnje in tako predstavlja visoko tehnično izobraženo strokovno podjetje. Poleg gradnje kakovostnih objektov želimo ves čas graditi tudi dobre poslovne odnose, ki so zasnovani na medsebojnem spoštovanju in zaupanju.

ADAPTABILITY

The system of prefabricated concrete structures is composed on type products, from which we can assemble a structure that perfectly fits your requirements. We understand all your needs and we are even able to anticipate them. Our manufacture is flexible enough to be able to follow even the most specific requirements. Therefore we are always ready to take a step further for your satisfaction.

RELIABILITY

Each object is special; each object presents a completely new challenge. We are therefore carefully monitoring quality and constantly looking for the possibilities for improvement. We always achieve the agreed standards or rather exceed them; our greatest satisfaction is a superbly constructed facility.

CORRECTNESS

Our company is created by people, who are continually furthering their knowledge, exchanging experience and thus contributing to improving the quality of business. We are also committed to the high business culture. Every day, every step we are building - as within the company, as well as with our business partners - good relations, based on respect and trust.

ABOUT
US

FOUNDATION
CUPS

COLUMNS

FLOOR
BEAMS

HOLLOW-
CORE
SLABS

DOUBLE
TT
SLABS

CRANE
GIRDERS

MAIN
BEAMS

PURLINS

MULTIPURPOSE
RECTANGULAR
BEAMS

FACADE
PANELS

LOADING
DOCKS

SYSTEM FOR
RESIDENTIAL
BUILDING

STAIRS

REF.
OBJECTS

PREPRIČLJIVI RAZLOGI

Montažna gradnja je gradnja prihodnosti

CONVINCING REASONS

Prefabricated construction is the future
of construction

PREPROSTO

Montažni sistemi zagotavljajo najpreprostejše rešitve za vse gradbene izzive v industriji in pri gradnji poslovnih zgradb, javnih objektov ter kmetijskih infrastruktur. Še več – te preproste rešitve imajo niz dodatnih prednosti. Ravno zato je montažna gradnja tako zanimiva.

SIMPLY

Prefabricated systems offer the simplest solutions to all the challenges in construction as in industry as well as in the construction of business or public buildings and agricultural facilities. Even more, these simple solutions deliver a range of additional benefits. Prefabricated construction is therefore all the more convincing.

EKONOMIČNO

Preproste rešitve, hitra izvedba in odlična kakovost odločilno vplivajo na ekonomičnost gradnje. Strokovna pomoč naših inženirjev dodatno poenostavi izvedbo projekta. Montažne betonske konstrukcije nudijo najboljše razmerje med ceno in kakovostjo.

ECONOMICALLY

Simple solutions, fast execution and overall quality of buildings have a decisive impact on the economical construction. Professional support of our engineers further contributes to the rational execution of projects. Prefabricated concrete structures offer the best ratio between price and quality.





EKOLOŠKO

Proizvodnja montažnih betonskih konstrukcij v kontroliranih pogojih v proizvodnji je že v osnovi ekološka. Naša odgovornost do okolja vključuje še več. Z natančnim načrtovanjem zmanjšujemo obremenitve naravnega okolja v fazi montaže objekta, posebno pozornost namenjamo tudi reciklaži objekta po izteku časa trajanja. Razmišljamo trajno, delujemo odgovorno.



HITRO

Koncept montažne gradnje je zasnovan ob zavedanju izjemnega pomena hitre realizacije idej. Naš sistem vključuje projektiranje, proizvodnjo betonskih elementov, transport in montažo objektov v zelo kratkem času. Glede na to, da delamo s prefabriciranimi elementi, zagotavljamo kakovostno gradnjo tudi pozimi.

ECO FRIENDLY

Manufacture of prefabricated concrete structures under controlled conditions, provided by the factory, is environmentally friendly in its essence. However, our responsibility to the environment is reaching even further. The burden on the environment at the stage of assembly is reduced through meticulous planning, whereas special attention is also devoted to the recycling of structures after the end of their useful life. We think sustainably, we act responsibly.

EFEKTIVNO

Naša tehnologija, izkušeni strokovnjaki in odlična organizacija zagotavljajo vrhunsko kakovost betonskih proizvodov in procesa izgradnje. Natančno načrtovani in pod strogim nadzorom izdelani prefabricirani gradbeni elementi so prilagojeni posebnim željam investitorjev in seveda zahtevam projektantov. Izpolnimo obljube in presegamo pričakovanja.

EFFECTIVELY

Our technology, experienced professionals and advanced organisation enable top quality concrete products and construction processes. Carefully designed and manufactured under strict surveillance, prefabricated construction elements can be adapted as to the requirements of their designers as well as to the special wishes of their investors. We accomplish promises and exceed expectations.

QUICKLY

The concept of prefabricated construction is based on our awareness of how important it is to realise the ideas quickly. Our system allows concrete elements design, manufacture, transportation as well as facility assembly in a very short time. All our components being manufactured in the factory, we ensure fast and quality construction even in the winter time.

ABOUT
US

FOUNDATION
CUPS

COLUMNS

FLOOR
BEAMS

HOLLOW-
CORE
SLABS

DOUBLE
TT
SLABS

CRANE
GIRDERS

MAIN
BEAMS

PURLINS

MULTIPURPOSE
RECTANGULAR
BEAMS

FACADE
PANELS

LOADING
DOCKS

SYSTEM FOR
RESIDENTIAL
BUILDING

STAIRS

REF.
OBJECTS

Temeljne čaše

Pocket foundations

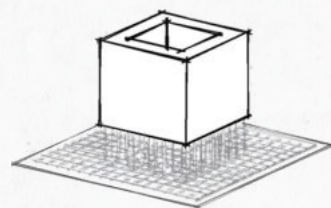

Temeljne čaše so prefabricirani elementi, ki se izdelujejo v posebnih kalupih v naših proizvodnih obratih pod ustreznim nadzorom. Z njihovo uporabo se bistveno zmanjša čas izgradnje temeljev, na podlagi tega pa se skrajšajo tudi roki izgradnje določenega objekta. Odvisno od statičnega izračuna se temeljne čaše izdelujejo iz betona kvalitete $C \geq 30/37$, medtem ko so dimenzije podane tabelarno v odvisnosti od dimenzij stebrov. Notranjost čaš je, zaradi boljše monolitizacije in lažje montaže stebrov, rebrasta in v naklonu. Končani prefabricirani elementi se odpeljejo s transportnim vozilom do mesta vgradnje. Čaše se montirajo na predhodno narejenem podložnem betonu, na katerega se skladno s projektom namesti ustrezna armatura točkovnih temeljev. Temeljne čaše se nato skupaj s točkovnimi temelji zalijejo z betonom na samem kraju, kar tvori temeljno celoto.

Pocket foundations are precast elements that are made in casting beds in our plants with proper supervision. Their use significantly reduces the time of footing realization, and therefore the deadline for building a particular facility is shortened. Depending on the static calculation, pocket foundations are made of concrete $C \geq 30/37$. The dimensions are given in the table below, depending on the dimensions of the columns. The inside of the pocket foundations is ribbed and sloped because of better monolithization and its mounting. Finished prefabricated elements are transported to the place of installation. Installation of the pocket foundations is done on the non-reinforced concrete base after setting the appropriate reinforcement of the footings. Footings are poured on - site, and together with the collars form a fundamental whole.

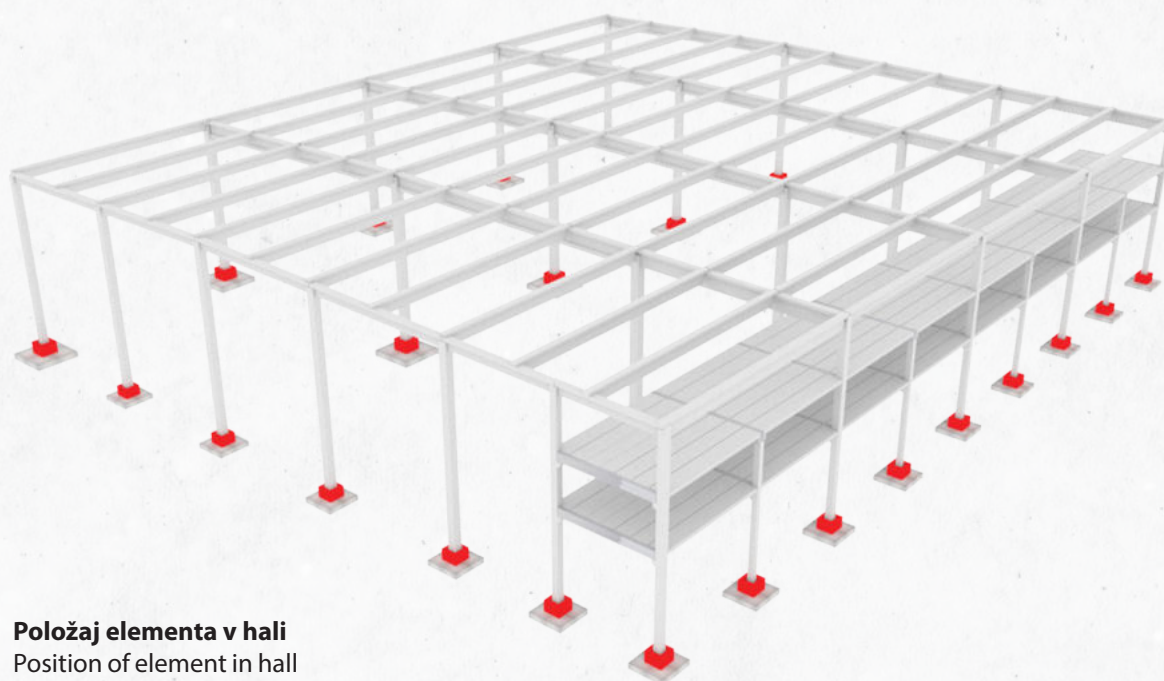

Položaj elementa v hali
Position of element in hall

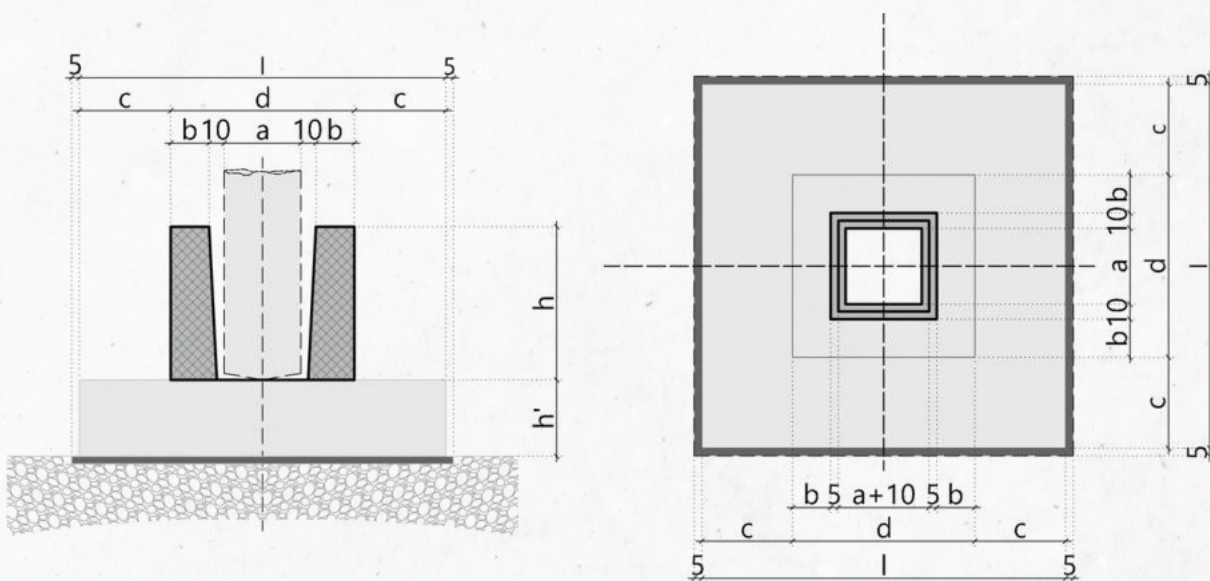

Tipi temeljnih čaš – geometrijske lastnosti

Type of pocket foundations-geometric characteristics

	dolžina / length (cm)
a	50 (60; 70; 80; 100)
b	20 (25)
c	50 (60)
d	$=(a+2b+20)$
l	$=(d+2c)$
h	80 (90; 100)
h'	40 (50; 60)



ABOUT
US

FOUNDATION
CUPS

COLUMNS

FLOOR
BEAMS

HOLLOW-
CORE
SLABS

DOUBLE
TT
SLABS

CRANE
GIRDERS

MAIN
BEAMS

PURLINS

MULTIPURPOSE
RECTANGULAR
BEAMS

FACADE
PANELS

LOADING
DOCKS

SYSTEM FOR
RESIDENTIAL
BUILDING

STAIRS

REF.
OBJECTS



Stebri

Columns

Prefabricirani stebri so vertikalni konstrukcijski elementi, ki nosijo elemente strehe, medetažne konstrukcije objektov, fasadne nosilce, nosilce žerjavnih prog in tudi »T« nosilce pri halah, ki so v naklonu. Stebri se montirajo na predhodno pripravljenih temeljih s temeljnimi čašami, lahko so kvadratnega in pravokotnega prereza. Kvaliteta betona je $C \geq 30/37$ v odvisnosti od statičnega izračuna. Del stebra, ki se vstavi v temeljno čašo, je zaradi boljše monolitizacije rebrast, na dnu pa je postavljen »trn« za natančno centriranje stebra med montažo. Na vrhu stebra, kjer nalega glavni nosilec, se pusti odprtina za povezavo.

Reinforced concrete columns are vertical structural elements that are carrying elements of the roof, plate floors, edge beams, crankshaft supports, as well as "T" carriers in objects which are denivelized. Columns are mounted on pre-prepared foundations with pocket foundations. Concrete class of columns is $C \geq 30 / 37$. The dimensions of the AB mounting column and console element date are tabular and depend on statics and architecture, can be square and rectangular cross-section. The part of the pocket foundations that enters the base cup is ribbed for better monolithization, and at the bottom is a "mandrel" for the precise centering of column during assembly. At the top of the column, where the main beam enters, there is left a hole for connection.

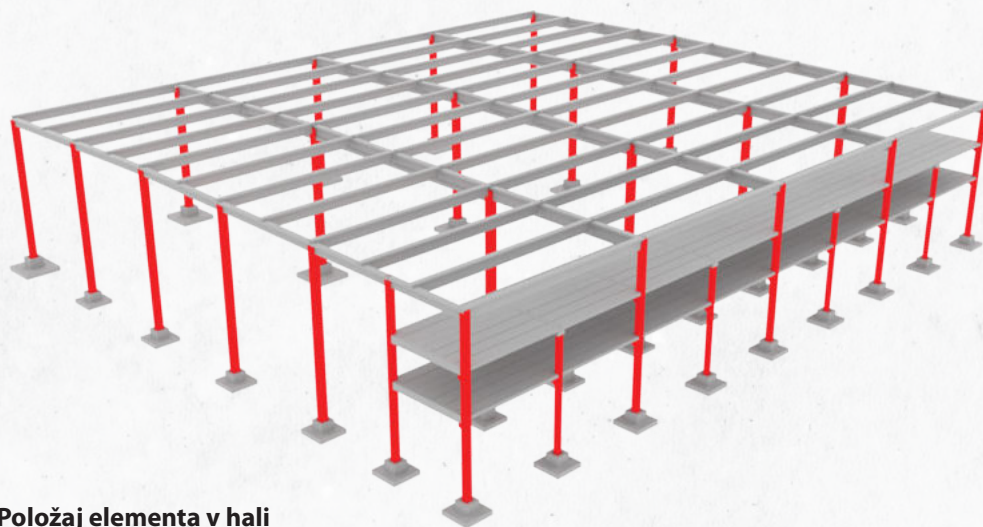

Položaj elementa v hali
Position of element in hall

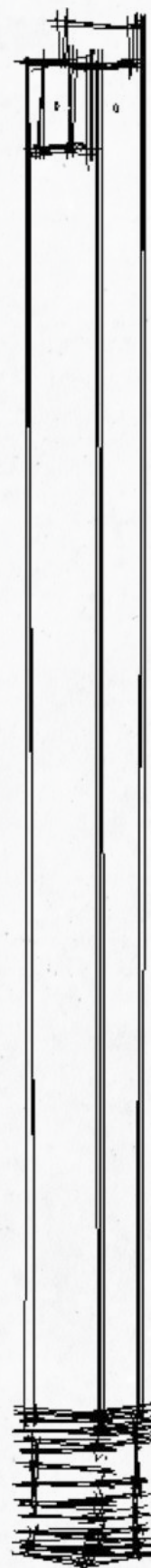



AB MONTAŽNI STEBRI / AB MOUNTING COLUMN

(samo za podpiranje glavnega nosilca)
(only for receiving the main carriers)

TIP 1 / TYPE 1

Prikaz glave stebra

Preview of capitel of a column

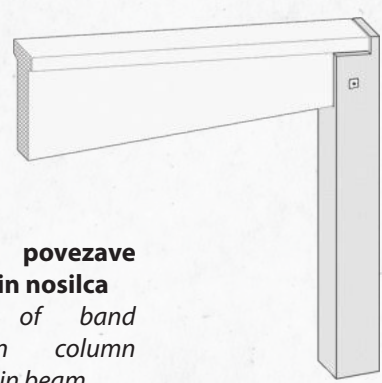
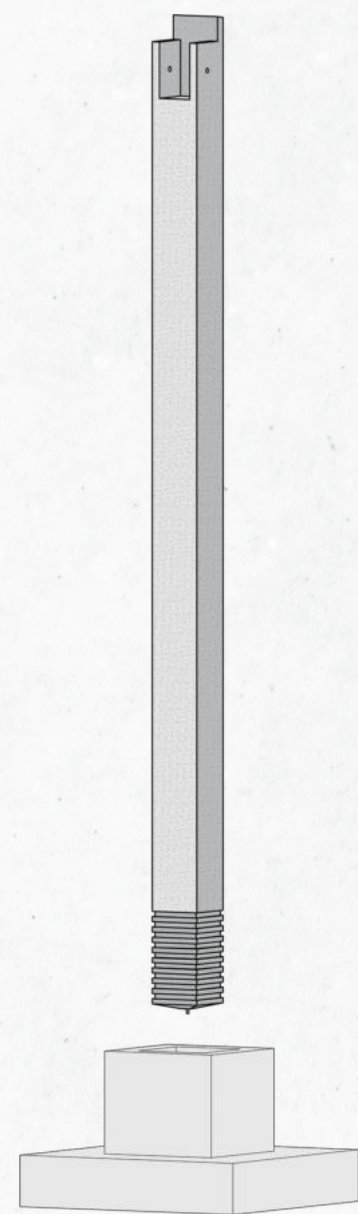
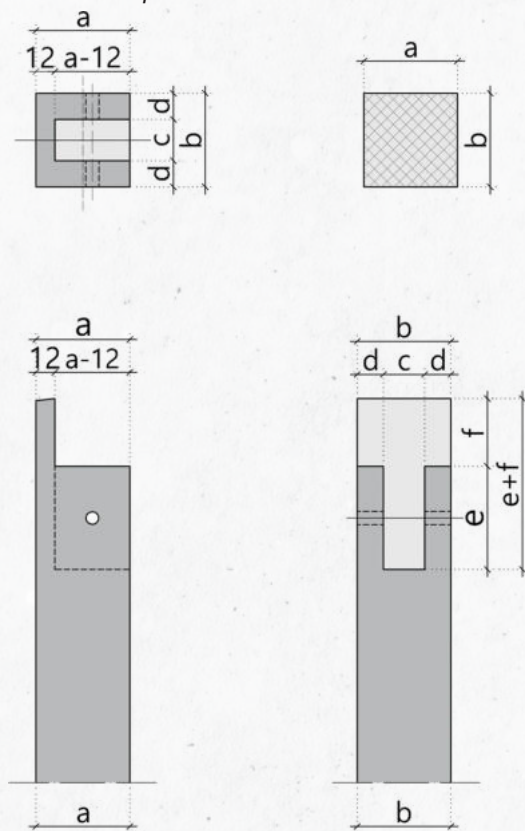

Detajl povezave stebra in nosilca
Detail of band between column and main beam

Tipi stebrov – geometrijske lastnosti

Type of columns foundations-geometric characteristics

	dolžina / length (cm)
a	50 (60; 70; 80; 100)
b	50 (60; 70; 80; 100)
c	18 (23; 32)
d	$= (b-c)/2$
e	38-155
f	0-35



REF. OBJEKTI
STOPNICE
SISTEM ZA GRADNJO STAVB
NAKLADALNE PLOŠČADI
FASADNI PANELI
VEČNAMENSKE PRAVOKOTNE GREDE
GREDE
GLAVNI NOSILCI
ŽERJAVNE PROGE
TT PLOŠČE
VOTLE PLOŠČE
MEDETAŽNI NOSILCI
STEBRI
TEMELJNE ČAŠE
O NAS

TIP 2 / TYPE 2

Detajl povezave stebra in nosilca
Detail of band between column and main beam

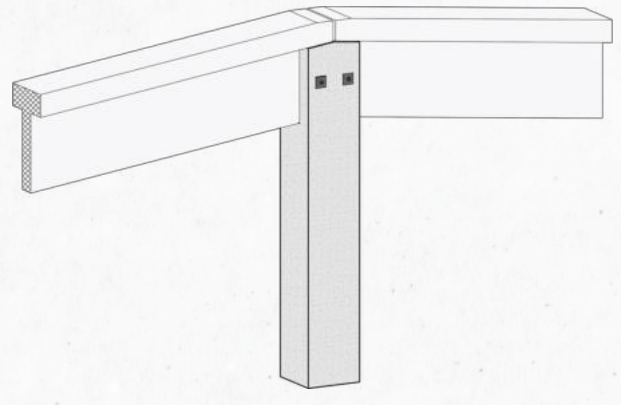

Prikaz glave stebra
Preview of capitel of a column

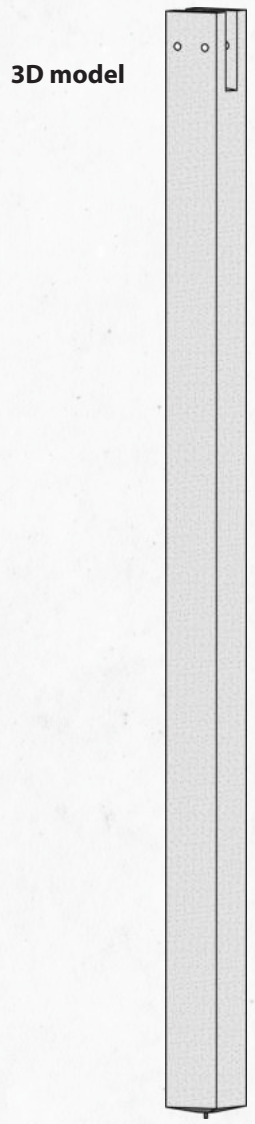
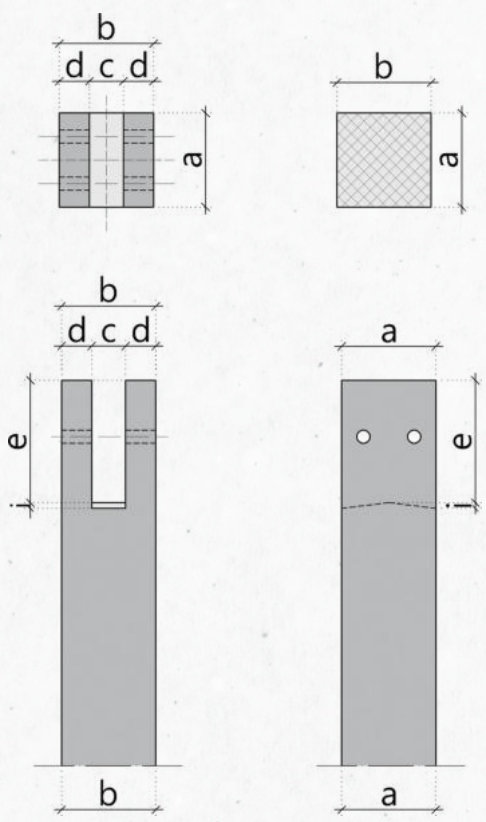

Tipi stebrov – geometrijske lastnosti
Type of columns foundations-geometric characteristics

	dolžina / length (cm)
a	50 (60; 70; 80; 100)
b	50 (60; 70; 80; 100)
c	18 (23;32)
d	$= (b-c)/2$
e	38-155

AB MONTAŽNI STEBRI / AB MOUNTING COLUMN

(dodatno podpiranje žerjavne proge in »T« nosilcev na različnih nivojih)
(additionally receive crankshaft supports and "T" carriers at the interchange)

TIP 1 / TYPE 1

Prikaz glave stebra

Preview of capitel of a column

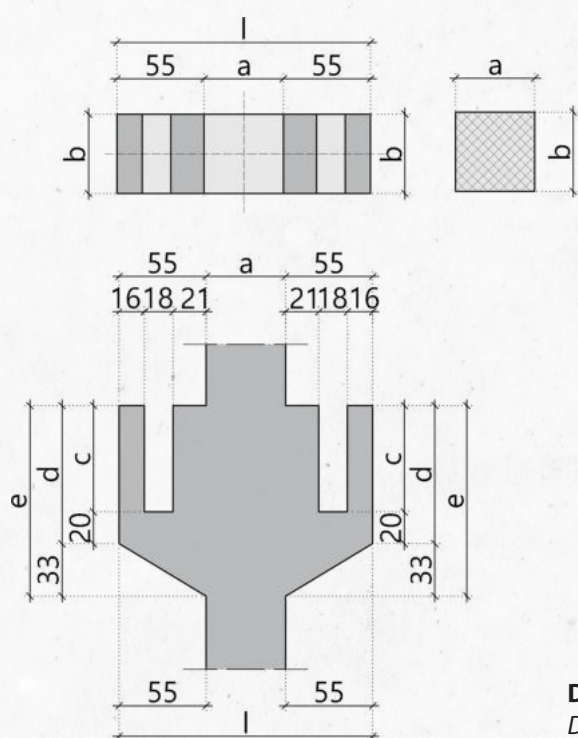

3D model

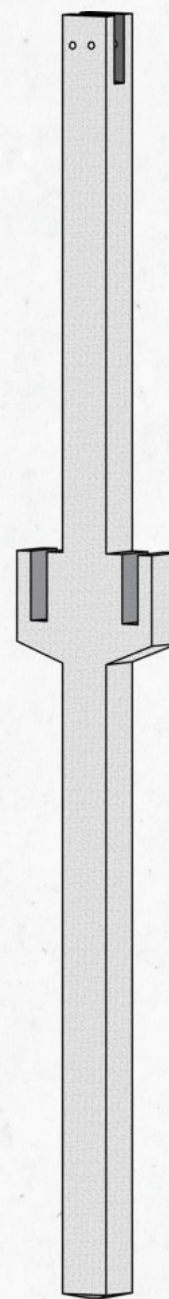

Detajl povezave stebra in nosilca

Detail of band between column and main beam

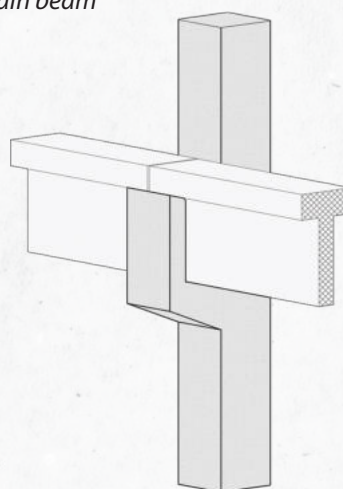

Tipi stebrov – geometrijske lastnosti

Type of columns - geometric characteristics

	dolžina / lenght (cm)
a	50 (60; 70; 80; 100)
b	50 (60; 70; 80; 100)
c	67 (87)
d	87 (107)
e	120 (140)
f	= (a+110)



REF. OBJEKTI
STOPNICE
SISTEM ZA GRADNJO STAVB
NAKLADALNE PLOŠČADI
FASADNI PANELI
VEČNAMENSKE PRAVOKOTNE GREDE
GREDBICE
GLAVNI NOSILCI
ŽERJAVNE PROGE
TT PLOŠČE
VOTLE PLOŠČE
MEDETAŽNI NOSILCI
STEBRI
TEMELJNE ČAŠE
O NAS

TIP 2 / TYPE 2

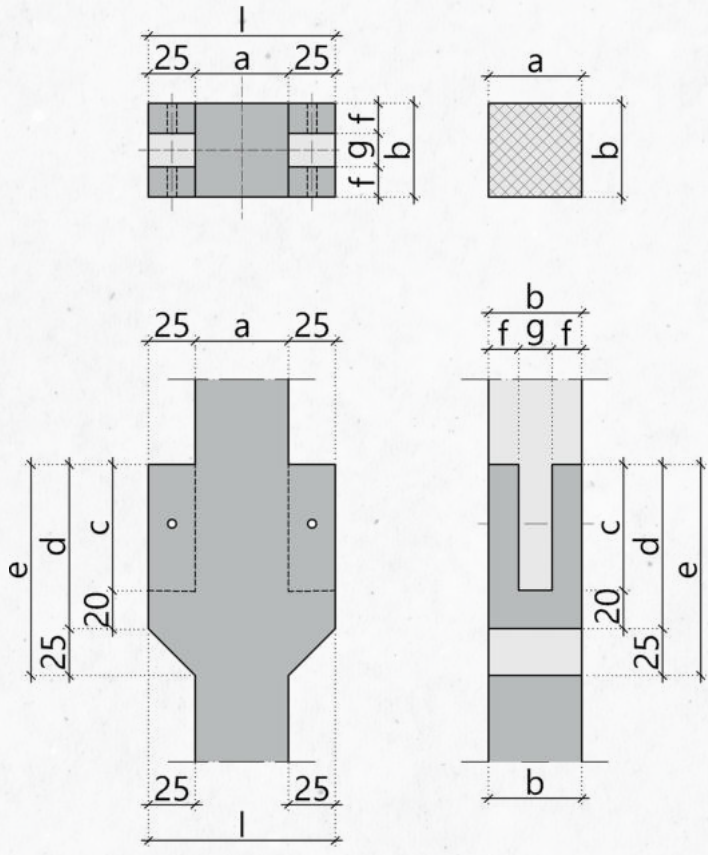

3D model

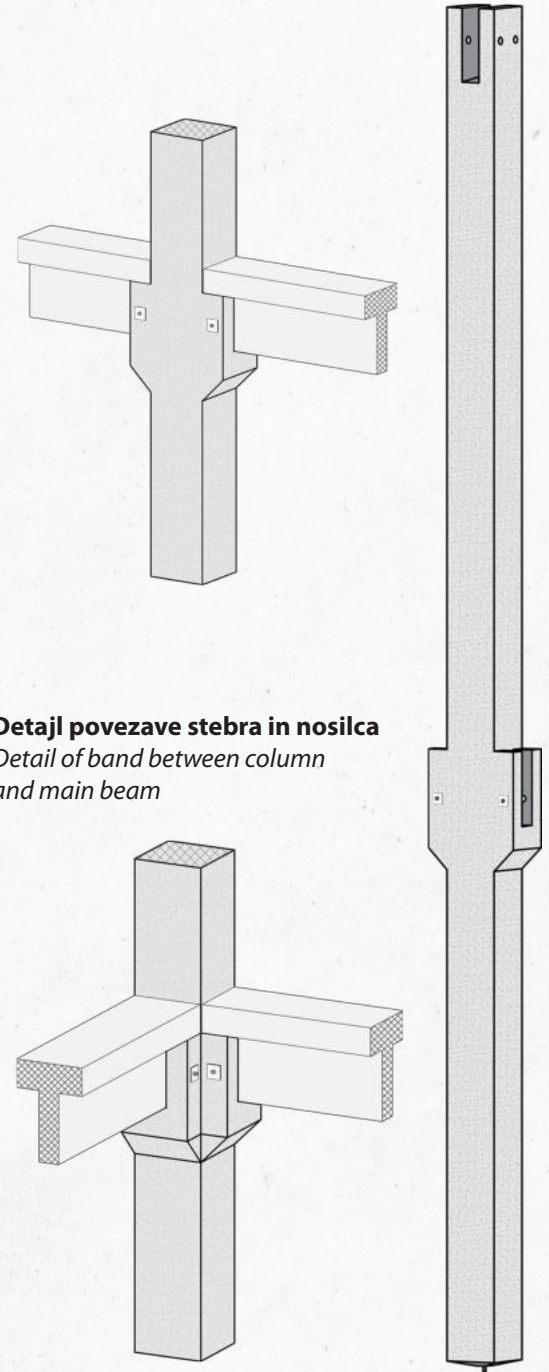

Detajl povezave stebra in nosilca
Detail of band between column and main beam

Tipi stebrov – geometrijske lastnosti
Type of columns - geometric characteristics

	dolžina / lenght (cm)
a	50 (60; 70; 80; 100)
b	50 (60; 70; 80; 100)
c	38-88
d	=(c+20)
e	=(d+25)
f	18 (23;32)
g	=(b-c)/2
l	=(a+50)



AB MONTAŽNI STEBRI / AB MOUNTING COLUMN

(dodatno podpiranje medetažnega nosilca na nivoju)
(additionally receive floor beams at their level)

TIP 1 / TYPE 1

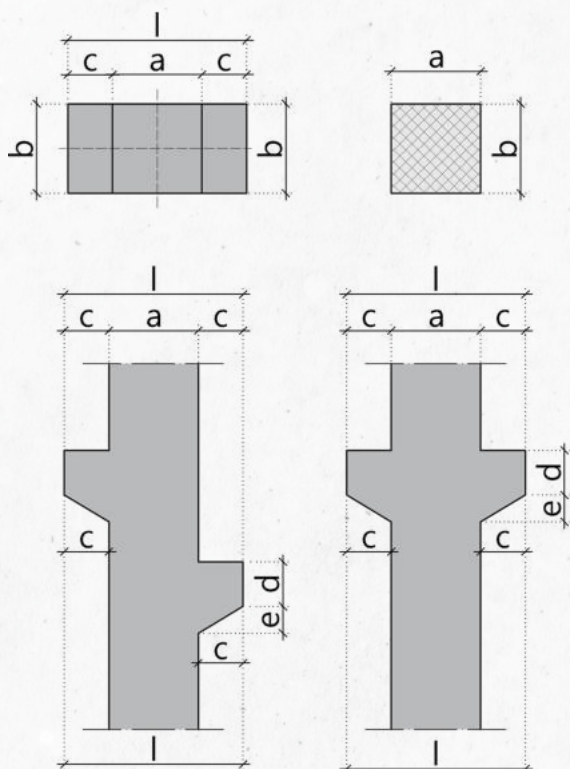

3D model



Detajl povezave stebra in nosilca
Detail of band between column
and main beam

Tipi stebrov – geometrijske lastnosti
Type of columns - geometric characteristics

	dolžina / length (cm)
a	50 (60; 70; 80; 100)
b	50 (60; 70; 80; 100)
c	67 (87)
d	87 (107)
e	120 (140)
f	= (a+110)



TIP 2 / TYPE 2

Prikaz glave stebra
Preview of capitel of a column

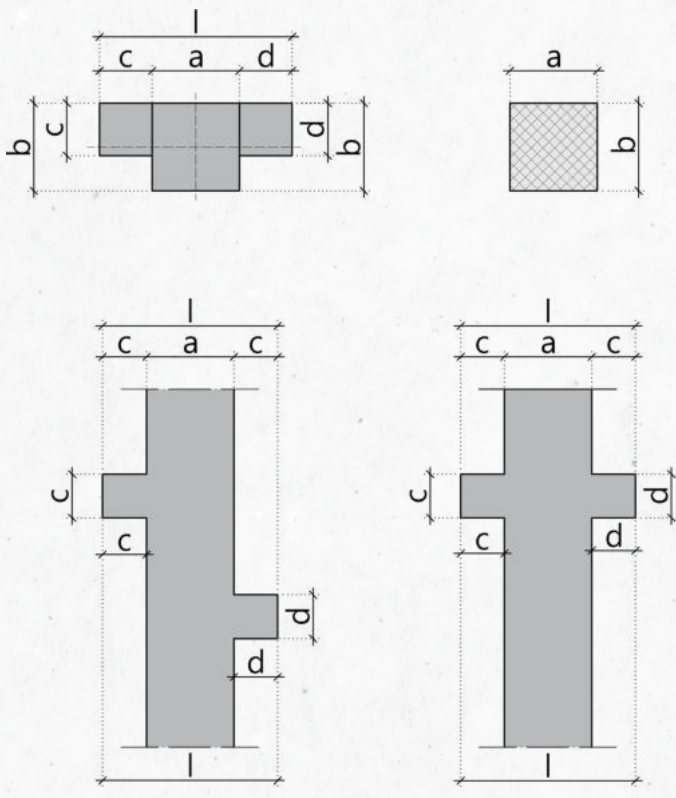

3D model

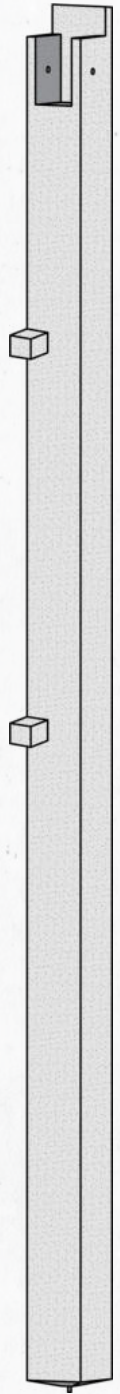

Detajl povezave stebra in nosilca
Detail of band between column and main beam

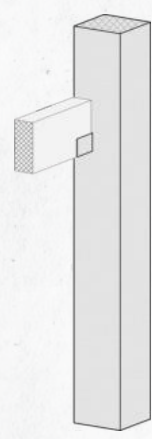

Tipi stebrov - geometrijske lastnosti
Type of colums - geometric characteristics

	dolžina / lenght (cm)
a	50 (60; 70; 80; 100)
b	50 (60; 70; 80; 100)
c	25-50
d	25-50
l	=(a+c+d)



ABOUT
US

FOUNDATION
CUPS

COLUMNS

FLOOR
BEAMS

HOLLOW-
CORE
SLABS

DOUBLE
TT
SLABS

CRANE
RIDERS

MAIN
BEAMS

PURLINS

MULTIPURPOSE
RECTANGULAR
BEAMS

FACADE
PANELS

LOADING
DOCKS

SYSTEM FOR
RESIDENTIAL
BUILDING

STAIRS

REF.
OBJECTS





O NAS

TEMELJNE ČAŠE

STEBRI

MEDETAŽNI NOSILCI

VOTLE PLOŠČE

TT PLOŠČE

ŽERJAVNE PROGE

GLAVNI NOSILCI

GREDICE

VEČNAMENSKE PRAVOKOTNE GREDE

FASADNI PANELI

NAKLADALNE PLOŠČADI

SISTEM ZA GRADNJO STAVB

STOPNICE

REF. OBJEKTI

Medetažni nosilci

Floor beam

Medetažni nosilci so konstrukcijski elementi za podpiranje votlih plošč. Nalegajo se na kratke stebrne elemente ali na vrhe stebrov. Dimenzije so podane tabelarno in so odvisne od statičnega izračuna ter višine votlih plošč. Lahko so srednji – obrnjen »T« prerez ali kotni – »L« prerez.

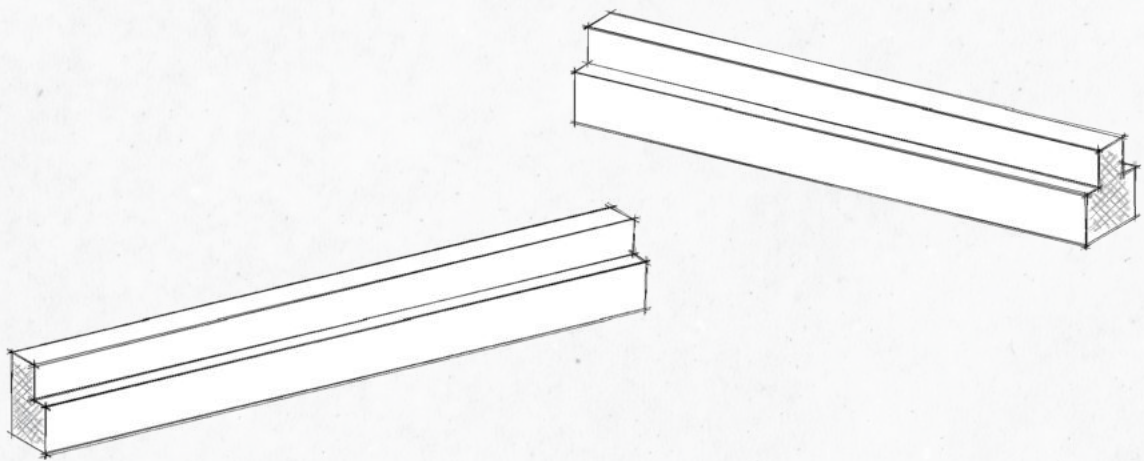

Floor beams are structural elements for carrying hollow-core slabs. They lay down on short elements or tops of columns. Dimensions are given in table below, and depend on the static calculation and height of the hollow-core slabs. They can be middle - reverse "T" and edge - "L" cross - section.

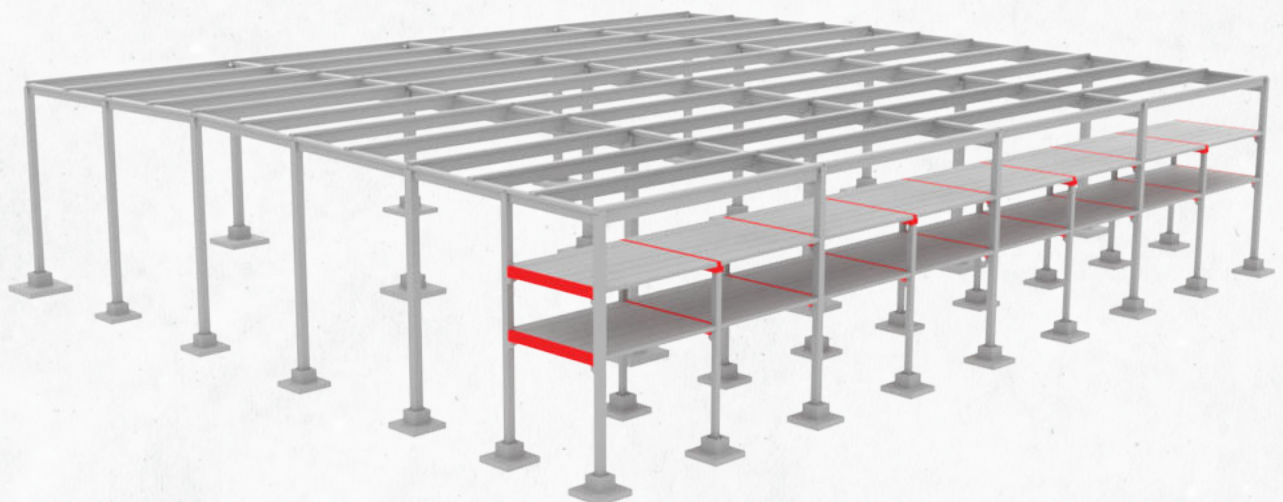

Položaj elementa v hali
Position of element in hall

MEDETAŽNI NOSILEC »L« PREREZA – tip 1 FLOOR BEAMS "L" CROSS-SECTION – type 1

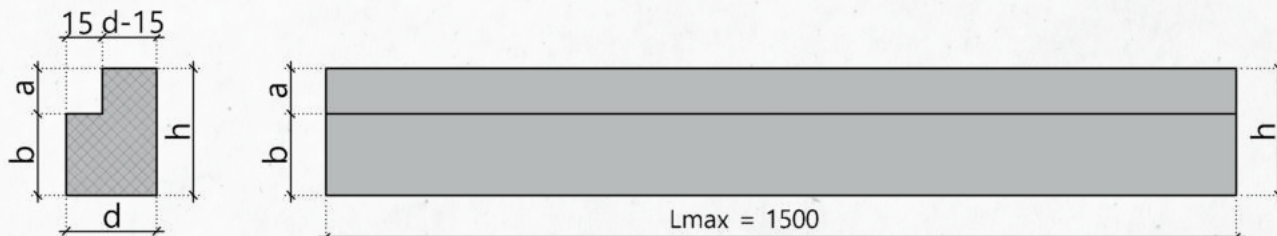

Tipi medetažnih nosilcev – geometrijske lastnosti
Type of pocket foundations - geometric characteristics

	dolžina / lenght (cm)
a	20-40
b	=(h-a)
h	50-130
d	50-90

MEDETAŽNI NOSILEC »L« PREREZA – tip 2 FLOOR BEAMS "L" CROSS-SECTION – type 2

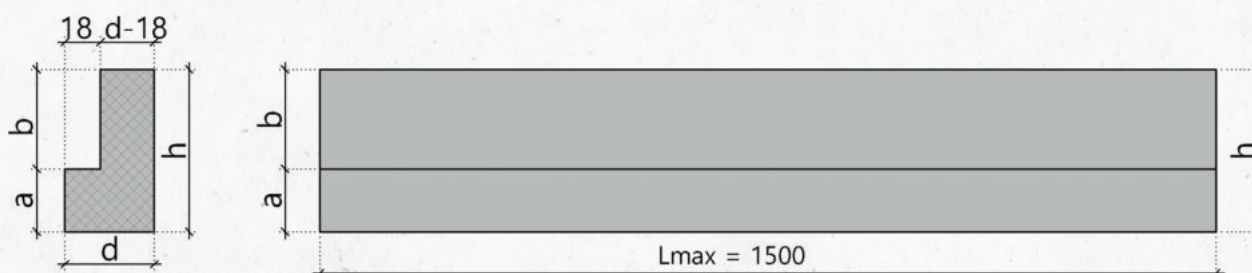

Tipi medetažnih nosilcev – geometrijske lastnosti
Type of pocket foundations - geometric characteristics

	dolžina / lenght (cm)
a	25, 35, 45, 55
b	=(h-a)
h	do 125
d	55-125



REF. OBJEKTI
STOPNICE
SISTEM ZA GRADNJO STAVB
NAKLADALNE PLOŠČADI
FASADNI PANELI
VEČNAMENSKE PRAVOKOTNE GREDE
GREDBICE
GLAVNI NOSILCI
ŽERJAVNE PROGE
TT PLOŠČE
VOTLE PLOŠČE
MEDETAŽNI NOSILCI
STEBRI
TEMELJNE ČAŠE
O NAS

OBRNJEN MEDETAŽNI NOSILEC »T« PREREZA – tip 1 FLOOR BEAMS REVERSE "T" - type 1

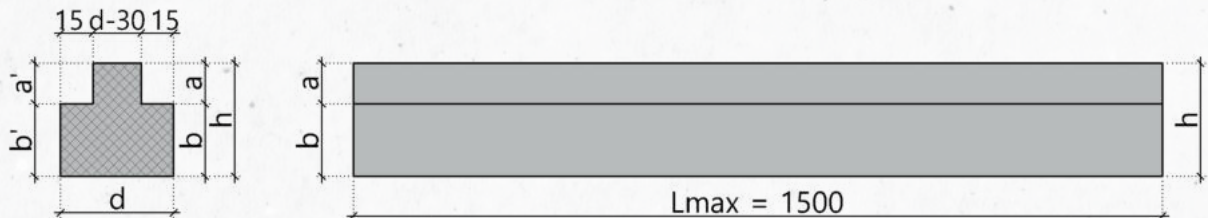

Tipi medetažnih nosilcev – geometrijske lastnosti
Type of pocket foundations - geometric characteristics

	dolžina / lenght (cm)
a	20-40
b	=(h-a)
a'	20-40
b'	=(h-a')
h	50-130
d	50-90

OBRNJEN MEDETAŽNI NOSILEC »T« PREREZA – tip 2 FLOOR BEAMS REVERSE "T" - type 2

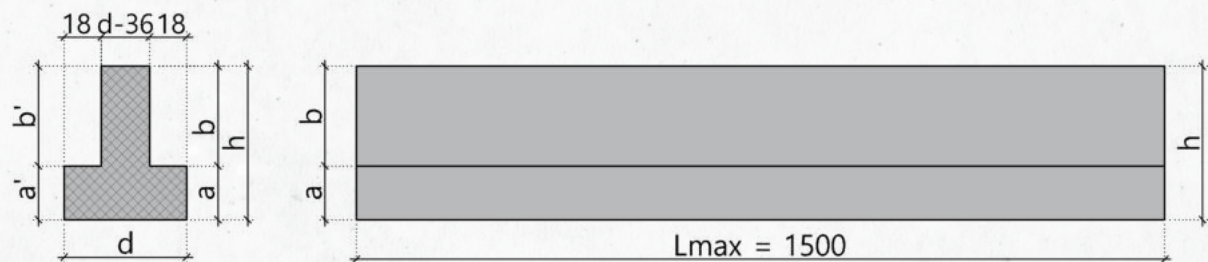

Tipi medetažnih nosilcev – geometrijske lastnosti
Type of pocket foundations - geometric characteristics

	dolžina / lenght (cm)
a	25, 35, 45, 55
b	=(h-a)
a'	25, 35, 45, 55
b'	=(h-a)
h	do 125
d	55-125



ABOUT
US

FOUNDATION
CUPS

COLUMNS

FLOOR
BEAMS

HOLLOW-
CORE
SLABS

DOUBLE
TT
SLABS

CRANE
GIRDERS

MAIN
BEAMS

PURLINS

MULTIPURPOSE
RECTANGULAR
BEAMS

FACADE
PANELS

LOADING
DOCKS

SYSTEM FOR
RESIDENTIAL
BUILDING

STAIRS

REF.
OBJECTS





O NAS

TEMELJNE
ČAŠE

STEBRI

MEDETAŽNI
NOSILCIVOTLE
PLOŠČETT
PLOŠČEŽERJAVNE
PROGEGLAVNI
NOSILCI

GREĐICE

VEČNAMENSKE
PRAVOKOTNE
GREĐEFASADNI
PANELINAKLADALNE
PLOŠČADISISTEM ZA
GRADNJO
STAVB

STOPNICE

REF.
OBJEKTI

Votle plošče

Hollow-core slabs

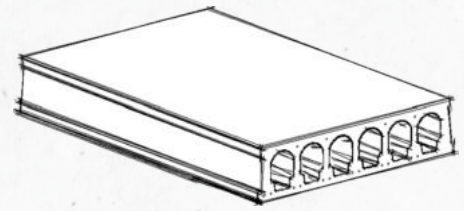

Prednapete votle plošče so montažni medetažni konstrukcijski elementi z neprekinjenimi notranjimi votlinami, ki bistveno zmanjšajo težo elementov. Proizvajajo se v širini 1.200 mm, vključno z vzdolžnimi spoji, medtem ko se v odvisnosti od razpona in obremenitve določata debelina in tip napenjanja. Narejene so iz betona kvalitete C=50/60. Po montaži prednapetih votlih plošč se naredi podlaga iz cementnega estriha za zaključna tla ali tlačna plošča, v kolikor so večje obremenitve. Standardne votle plošče so ognjevarne od 60 do 120 minut. Ena izmed glavnih prednosti teh plošč je hitra vgradnja, brez potrebe podpiranja. Teža plošč je od 27 % do 54 % manjša od običajnih monolitnih plošč, kar zmanjšuje dimenzije ostalih elementov nosilne konstrukcije.

Pre-stressed hollow core slabs are prefabricated structural elements with continuous inner holes, which significantly reduce the weight of the elements, and thus "comes" to the savings in concrete and reinforcement, depending on the range and load, the thickness and type of weights are determined. Producers width is 1200 mm, inclusive of the longitudinal joint, while depending on the range and load, the thickness and type of weights are determined. The hollow core slabs are made of concrete C=50/60. After installation of prestressed hollow core slabs, the workmanship of cement base follows as a base for the final floor. One of the main advantages of these boards is fast installation, with no need for support. Also, the weight of these boards is from 37% up to 54% less than the usual monolithic slabs, which reduces the dimensions of the other elements of the supporting structure.

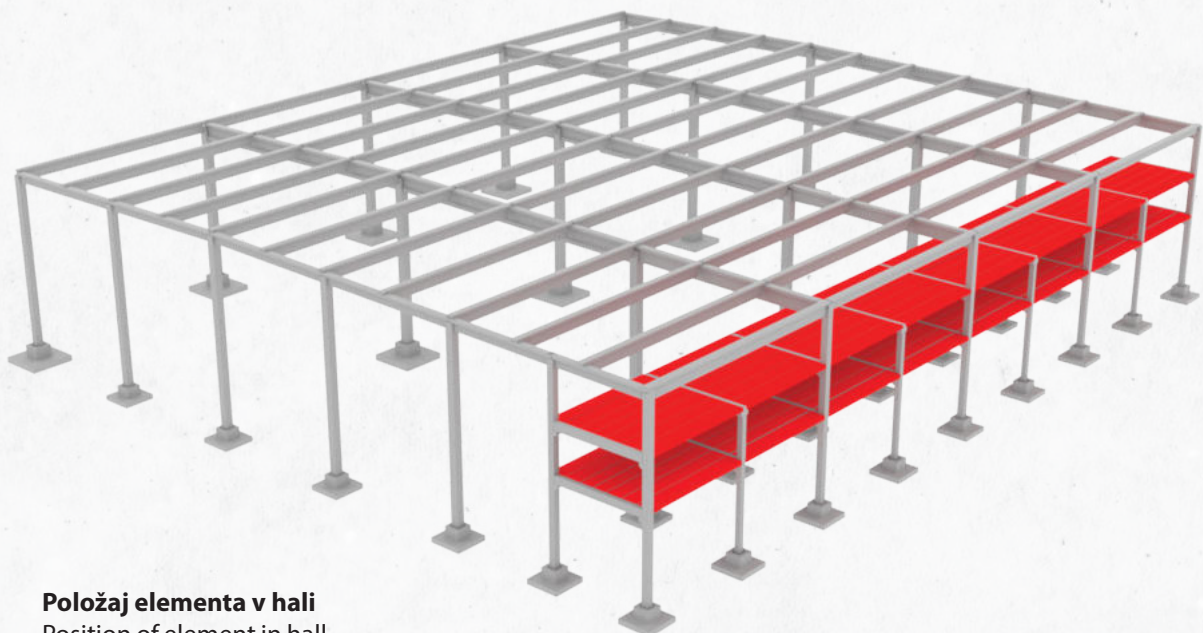







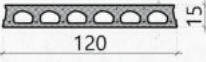
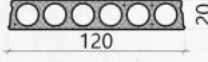

Položaj elementa v hali
Position of element in hall

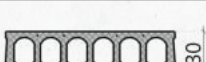

Tipi votlih plošč – geometrijske lastnosti

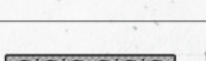
Type of hollow-core slabs - geometric characteristics

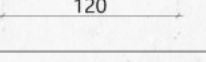
ECHO		ELEMATIC	
SC 15x120 dolžina do 7 m		SC 20x120 dolžina do 11 m	
SC 20x120 dolžina do 11 m		SC 26.5x120 dolžina do 12 m	
SC 25x120 dolžina do 12 m		SC 32x120 dolžina do 14 m	
SC 30x120 dolžina do 14 m		SC 40x120 dolžina do 17 m	
SC 35x120 dolžina do 15 m		SC 50x120 dolžina do 20 m	
SC 40x120 dolžina do 17 m			



Odporne proti zvoku
Sound resistant

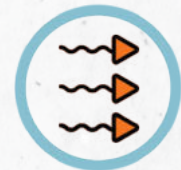

Odporne proti toploti
Heat resistant



Odporne proti ognju
Fire resistant



Lahke
Light weight

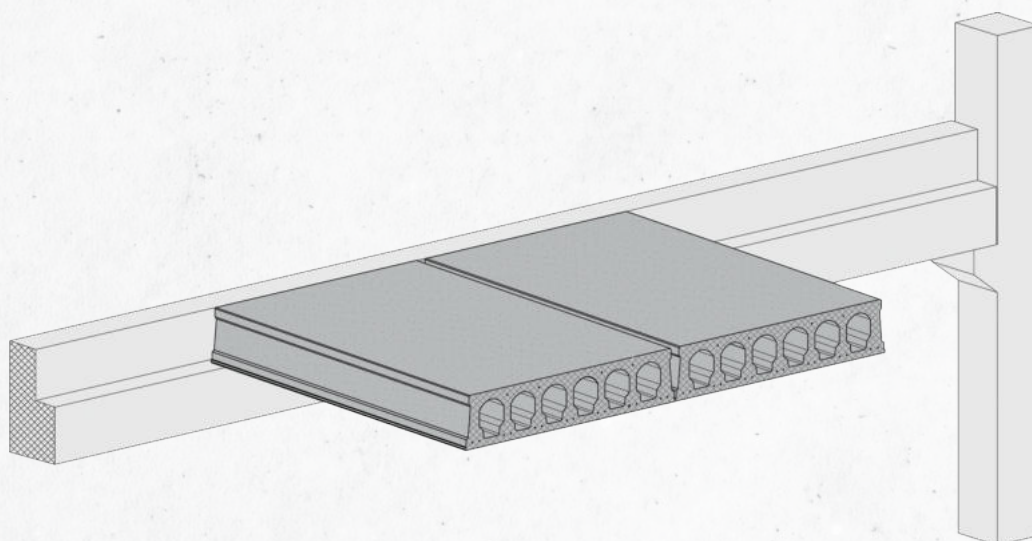

ABOUT US
FOUNDATION CUPS
COLUMNS
FLOOR BEAMS
HOLLOW-CORE SLABS
DOUBLE TT SLABS
CRANE GIRDERS
MAIN BEAMS
PURLINS
MULTIPURPOSE RECTANGULAR BEAMS
FACADE PANELS
LOADING DOCKS
SYSTEM FOR RESIDENTIAL BUILDING
STAIRS
REF. OBJECTS



O NAS

TEMELJNE
ČAŠE

STEBRI

MEDETAŽNI
NOSILCI

VOTLE
PLOŠČE

TT
PLOŠČE

ŽERJAVNE
PROGE

GLAVNI
NOSILCI

GREDICE

VEČNAMENSKE
PRAVOKOTNE
GREDE

FASADNI
PANELI

NAKLADALNE
PLOŠČADI

SISTEM ZA
GRADNJO
STAVB

STOPNICE

REF.
OBJEKTI

Odprtine za stopnice, kamine in strešna okna, če nimajo druge podpore, se lahko naredijo s konstrukcijo nadomestnih nosilcev (menjalnik). Nadomestni nosilec se dostavi skupaj s prednapetimi votlimi ploščami.

Openings for stairs, fireplaces and roof windows, if there is no other support, can be made by the construction of replacement girders. The replacement girder is supplied with hollow-core slabs.

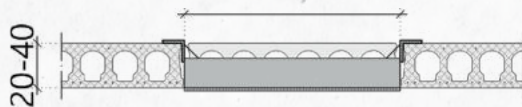

nadomestni nosilec - menjalnik
replacement girder

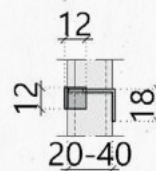
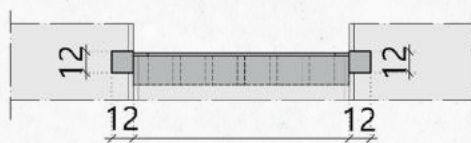

3D model

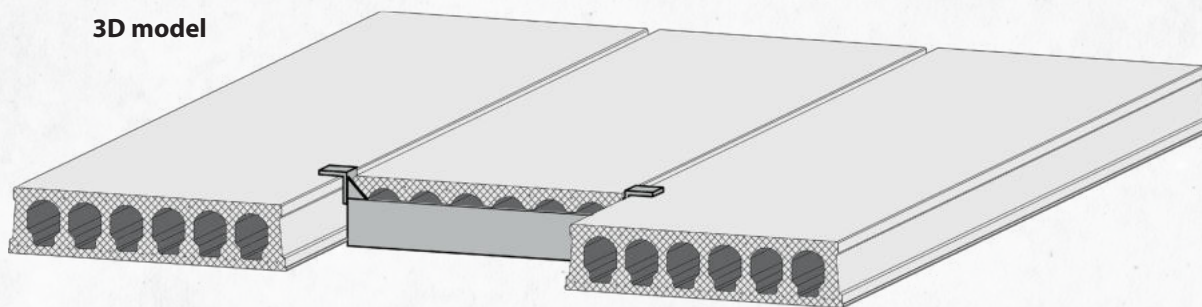



- ABOUT US
- FOUNDATION
- CUPS
- COLUMNS
- FLOOR BEAMS
- HOLLOW-CORE SLABS**
- DOUBLE TT SLABS
- CRANE GRIDDERS
- MAIN BEAMS
- PURLINS
- MULTIPURPOSE RECTANGULAR BEAMS
- FACADE PANELS
- LOADING DOCKS
- SYSTEM FOR RESIDENTIAL BUILDING
- STAIRS
- REF. OBJECTS

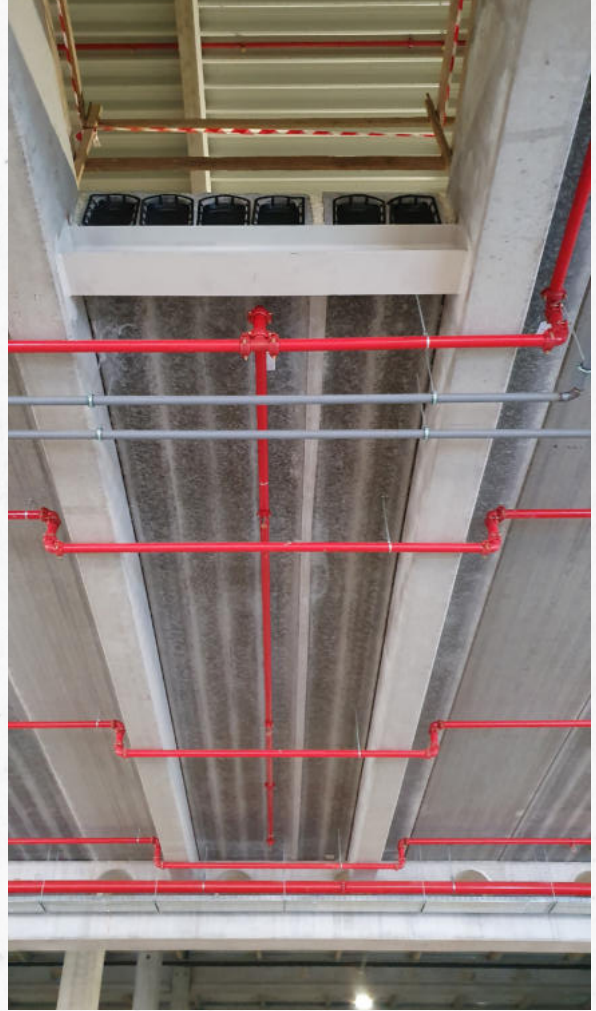



O NAS

TEMELJNE ČASE

STEBRI

MEDETAŽNI NOSILCI

VOTLE PLOŠČE

TT PLOŠČE

ŽERJAVNE PROGE

GLAVNI NOSILCI

GREĐICE

VEČNAMENSKE PRAVOKOTNE GREDE

FASADNI PANELI

NAKLADALNE PLOŠČADI

SISTEM ZA GRADNJO STAVB

STOPNICE

REF. OBJEKTI

TT (pi) plošče

TT (pi) double tee

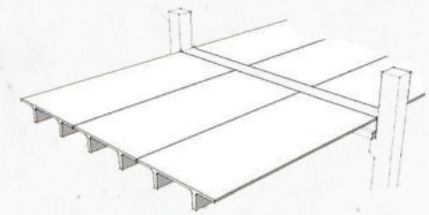

TT plošče ponujajo lep izgled in prilagodljivost v obliki. Ti prefabricirano-prednapeti betonski elementi so idealni za talne in strešne sisteme, ki zahtevajo dolge, neprekinjene razpone. Imajo visoko požarno odpornost. TT plošče so montažni elementi, narejeni iz prednapetega betona kvalitete C=50/60. Standardne širine TT plošč so do 250 cm, z rebrastim prečnim prerezom. Na ploščah se lahko izdelajo tudi vdolbine. Na robovih se lahko naredijo tudi okrogle odprtine za različne vrste instalacij. Položaj in dimenzije vdolbin ter odprtin morajo biti vnaprej določeni, ker zmanjšujejo nosilnost plošč.

TT boards enable rapid construction and flexibility in design. These prefabricated - pre-stressed concrete units are ideal for floor and roof systems that require long, continuous ranges. They have high fire resistance. TT slabs are prefabricated elements made of prestressed concrete C=50/60. They are used for the construction of floor structures. The nominated widths of TT units are 250cm, with ribbed cross-section and a smooth under face. In the slabs recesses can be profiled. In the edges, round openings can be made for different types of installations. The position and dimensions of the recesses and holes must be pre-defined, because they reduce the load bearing capacity of a slab.

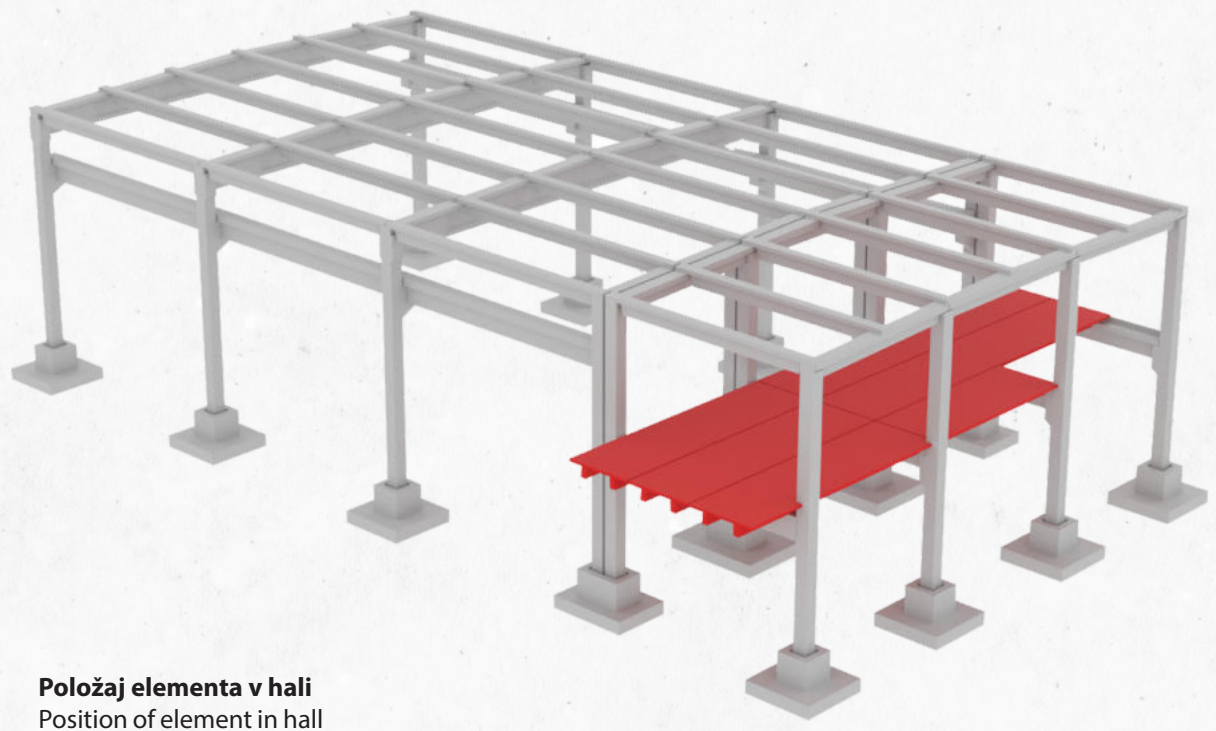

Položaj elementa v hali
Position of element in hall

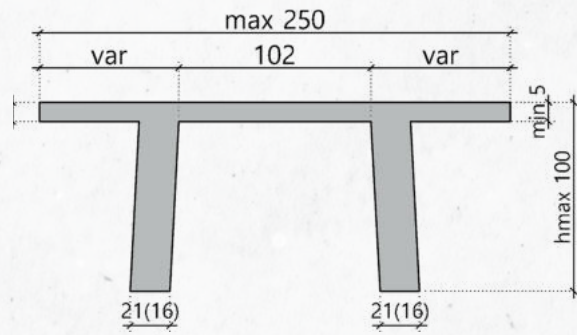
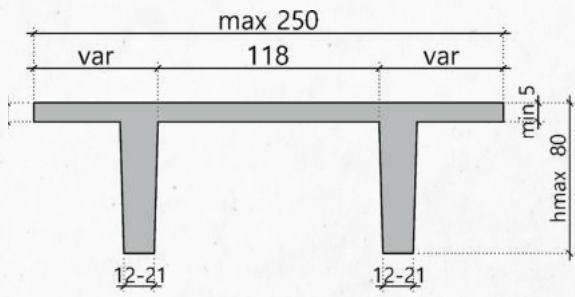

- ABOUT US
- FOUNDATION
- CUPS
- COLUMNS
- FLOOR BEAMS
- HOLLOW-CORE SLABS
- DOUBLE-TT SLABS**
- CRANE GIRDERS
- MAIN BEAMS
- PURLINS
- MULTIPURPOSE RECTANGULAR BEAMS
- FACADE PANELS
- LOADING DOCKS
- SYSTEM FOR BUILDING
- STAIRS
- REF. OBJECTS



O NAS

TEMELJNE ČAŠE

STEBRI

MEDETAŽNI NOSILCI

VOTLE PLOŠČE

TT PLOŠČE

ŽERJAVNE PROGE

GLAVNI NOSILCI

GREĐICE

VEČNAMENSKE PRAVOKOTNE GREDE

FASADNI PANELI

NAKLADALNE PLOŠČADI

SISTEM ZA GRADNJO STAVB

STOPNICE

REF. OBJEKTI

Žerjavne proge

Crane girders

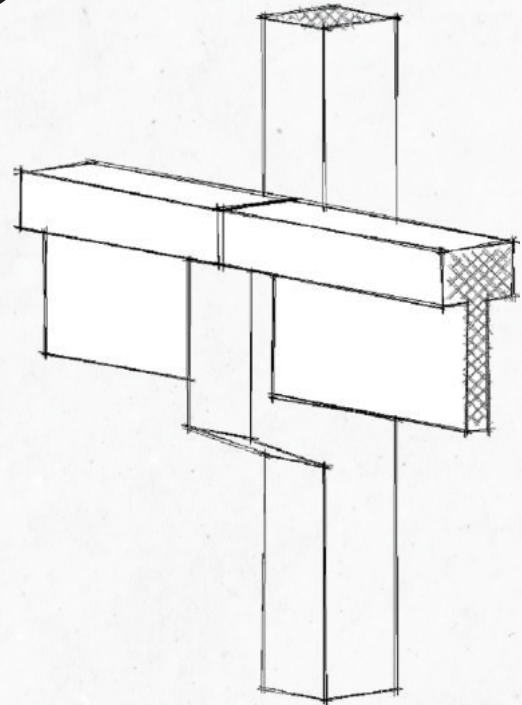

Žerjavne proge ali nosilci dvigal so elementi, ki so nameščeni neposredno pod tirnico in služijo kot nosilna konstrukcija, po kateri se dvigalo premika. Podpirajo se neposredno prek stebrov ali konzol. Glavni nosilci, ki lahko nosijo žerjavne proge, so T 80, T 90, T 100 in T 120.

Crane girders or crane supports are elements that are positioned just below the rail and serve as the supporting structure on which the crane is moving. Their backrests are carried out directly through the pillars or through the console of the frame main beams of the hall. The main beams that make the crane girders are T 90, T 100 and T 120.

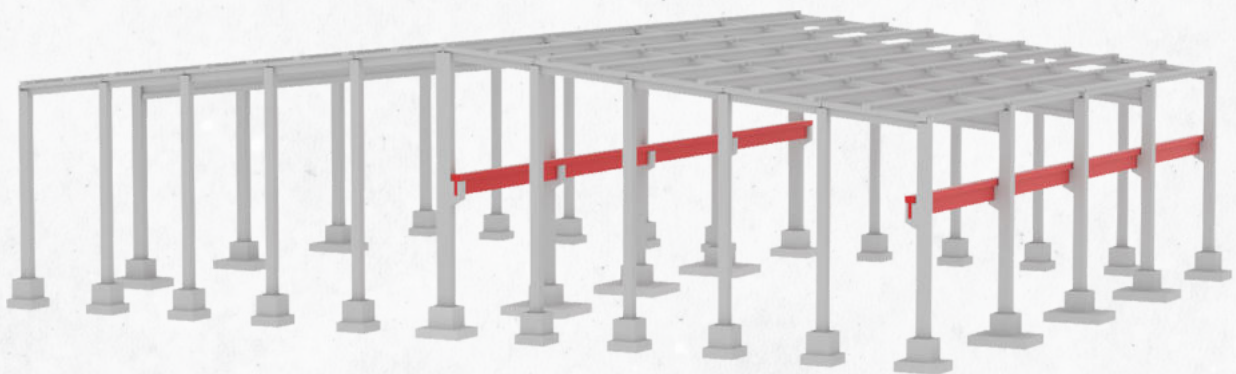

Položaj elementa v hali
Position of element in hall

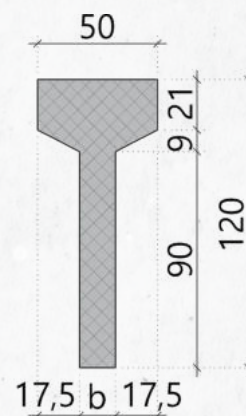
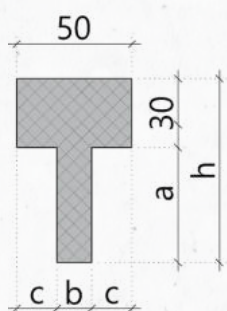

Tipi žerjavnih prog – geometrijske lastnosti
Type of crane girders - geometric characteristics

	dolžina / length (cm)
a	60 (70)
b	15 (20)
c	17,5 (15)
h	a+30

	dolžina / length (cm)
b	15 (20)





- O NAS
- TEMELJNE ČAŠE
- STEBRI
- MEDETAŽNI NOSILCI
- VOTLE PLOŠČE
- TT PLOŠČE
- ŽERJAVNE PROGE
- GLAVNI NOSILCI**
- GREDICE
- VEČNAMENSKE PRAVOKOTNE GREDE
- FASADNI PANELI
- NAKLADALNE PLOŠČADI
- SISTEM ZA GRADNJO STAVB
- STOPNICE
- REF. OBJEKTI

Glavni nosilci

Main beams

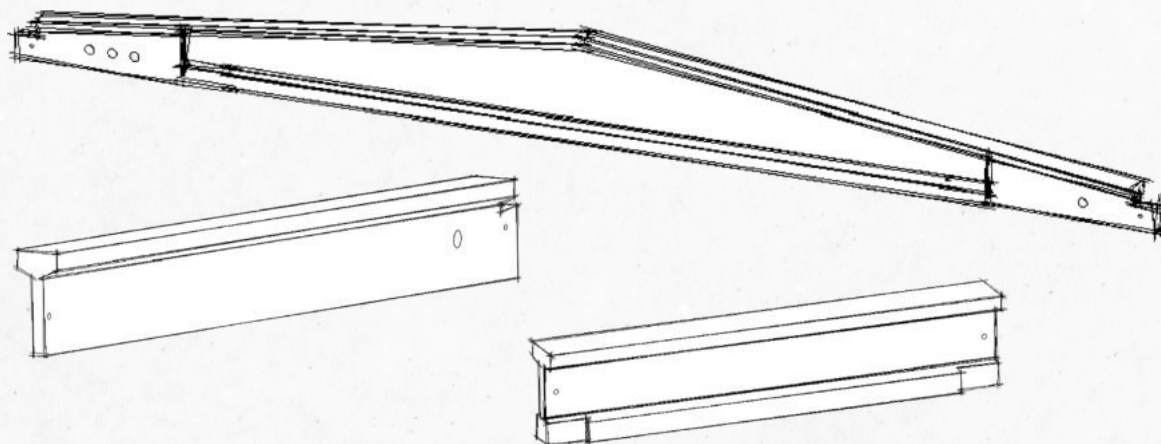

Glavni nosilci so prednapeti, horizontalni, nosilni konstrukcijski elementi, ki podpirajo sekundarne nosilce in votle plošče. Narejeni so iz betona kvalitete $C \geq 40/50$ in so različnih tipov napenjanja v odvisnosti od statičnega izračuna. Dimenzije prečnega prereza so podane tabelarno in so odvisne od razpona ter pripadajoče vplivne površine. Nalegajo se na vrhe stebrov.

Main beams are prestressed elements for receiving secondary beams, hollow-core slabs etc. Concrete that is used is $C \geq 40 / 50$ and there are different types of weights depending on static calculation. The cross-section dimensions are given in a table below and depend on the range and the associated bearing surface. They lay down at the top of the columns.

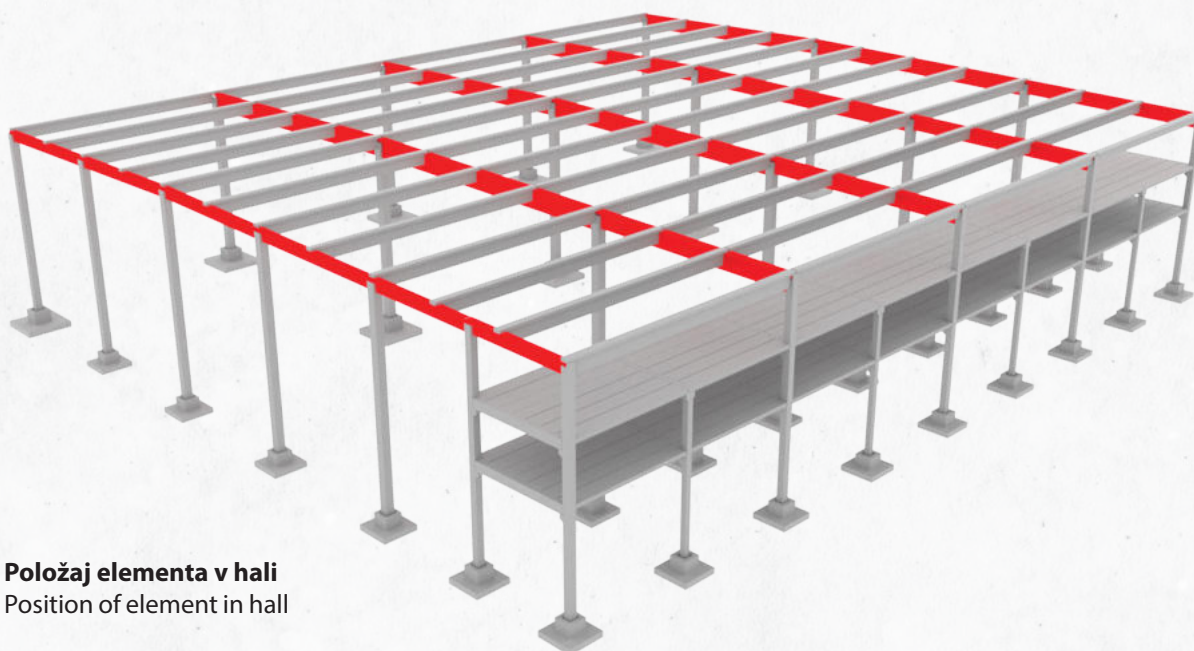

Položaj elementa v hali
Position of element in hall

PREDNAPETI »I« NOSILEC PRESTRESSED "I" BEAM

»I« nosilci so prednapeti elementi, ki podpirajo sekundarne nosilce in votle plošče. Kvaliteta betona, ki se uporablja, je $C \geq 40/50$. Obstajajo različni tipi napenjanja v odvisnosti od statičnega izračuna. Požarna odpornost je 60 minut. Dimenzije prečnega prereza so podane tabelarno in so odvisne od razpona ter pripadajoče vplivne površine. Nalegajo se na vrhe stebrov.

"I" Beams are prestressed elements for receiving secondary beams, hollow-core slabs etc. Concrete that is used is $C \geq 40 / 50$. There are different types of weights depending on static calculation. Fire resistance to 60 minutes. The cross-section dimensions are given in a table below and depend on the range and the associated bearing surface. They lay at the top of the columns.

»I« nosilec 140 / "I" Beam 140

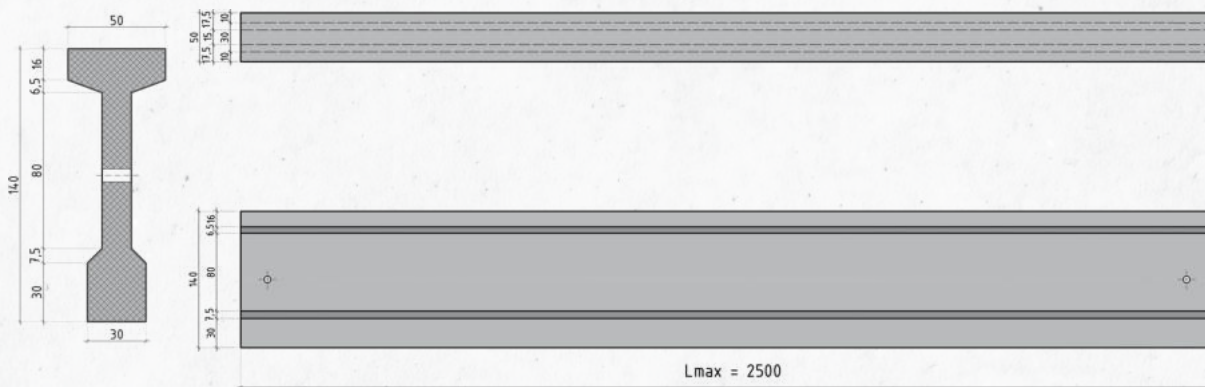

»I« nosilec 170 / "I" Beam 170

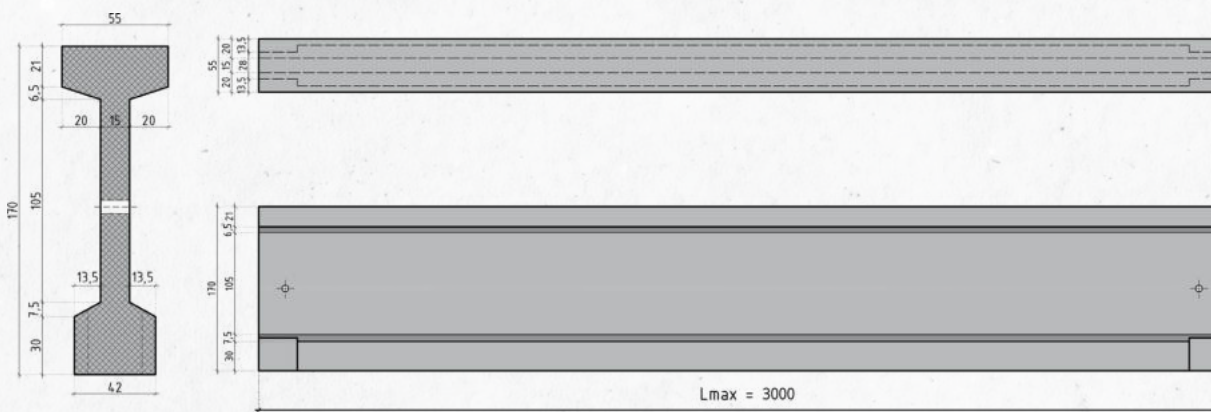

Tipi nosilcev – geometrijske lastnosti
Type of pocket foundations-geometric characteristics

	dolžina / length (cm)
a	70 - 115
h	140 - 170



- O NAS
- TEMELJNE ČAŠE
- STEBRI
- MEDETAŽNI NOSILCI
- VOTLE PLOŠČE
- TT PLOŠČE
- ŽERJAVNE PROGE
- GLAVNI NOSILCI
- GREDICE
- VEČNAMENSKE PRAVOKOTNE GREDE
- FASADNI PANELI
- NAKLADALNE PLOŠČADI
- SISTEM ZA GRADNJO STAVB
- STOPNICE
- REF. OBJEKTI

PREDNAPETI »A« NOSILEC PRESTRESSED "A" BEAM

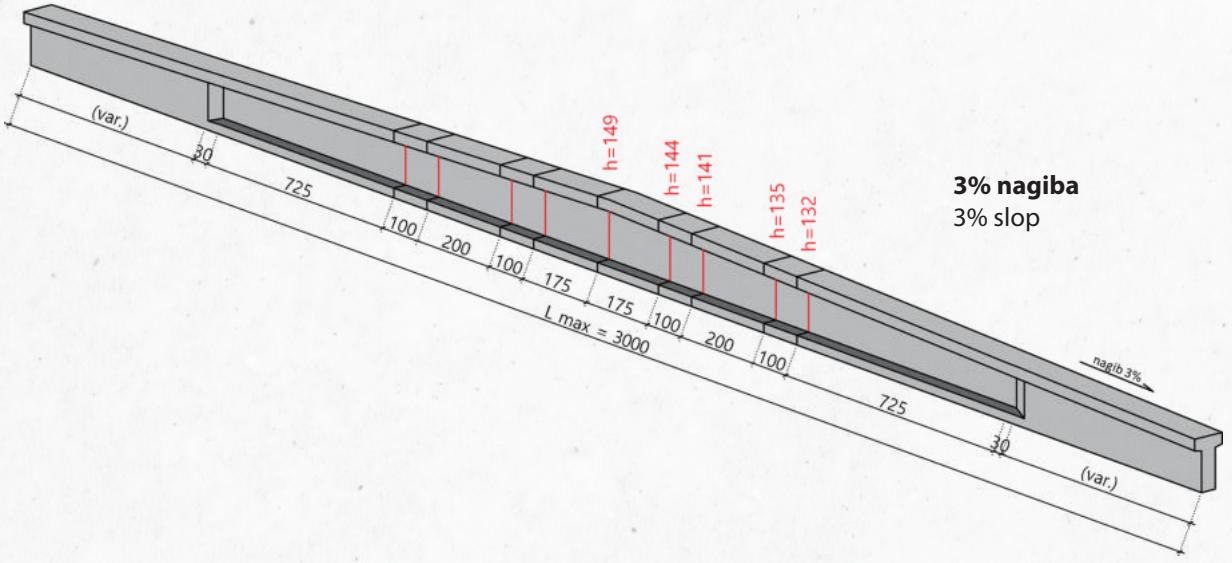

3% nagiba
3% slop

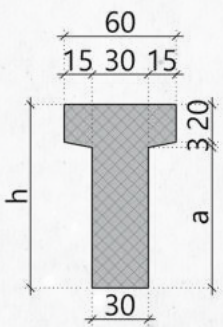

Tipi nosilcev – geometrijske lastnosti
Type of beam - geometric characteristics

	dolžina / lenght (cm)
a	h - 23
h	var.

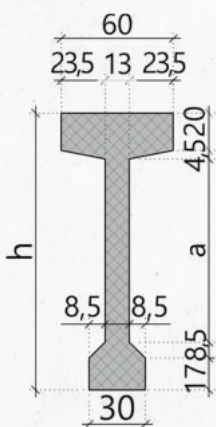

Tipi nosilcev – geometrijske lastnosti
Type of beam - geometric characteristics

	dolžina / lenght (cm)
a	h - 50
h	var. (max 149)



- ABOUT US
- FOUNDATION CUPS
- COLUMNS
- FLOOR BEAMS
- HOLLOW-CORE SLABS
- DOUBLE-T SLABS
- CRANE GIRDERS
- MAIN BEAMS**
- PURLINS
- MULTIPURPOSE RECTANGULAR BEAMS
- FACADE PANELS
- LOADING DOCKS
- SYSTEM FOR RESIDENTIAL BUILDING
- STAIRS
- REF. OBJECTS

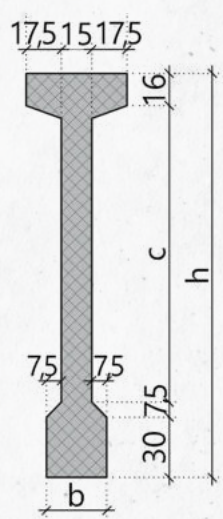
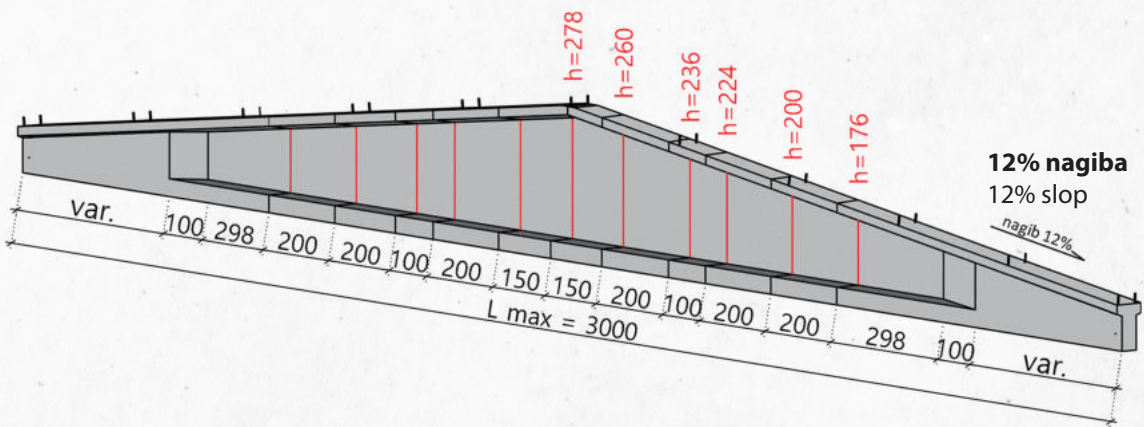

Tipi nosilcev – geometrijske lastnosti
Type of beam - geometric characteristics

	dolžina / length (cm)
a	50 (55)
b	30 (35)
c	= (h-53.3)
h	var. (max 278)

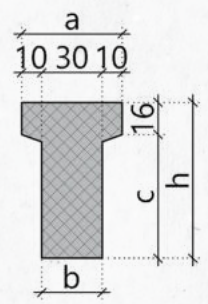

Tipi nosilcev – geometrijske lastnosti
Type of beam - geometric characteristics

	dolžina / length (cm)
a	50 (55)
b	30 (35)
c	= (h-16)
h	var.



O NAS

TEMELJNE
ČAŠE

STEBRI

MEDETAŽNI
NOSILCI

VOTLE
PLOŠČE

TT
PLOŠČE

ŽERJAVNE
PROGE

GLAVNI
NOSILCI

GREDICE

VEČNAMENSKE
PRAVOKOTNE
GREDE

FASADNI
PANELI

NAKLADALNE
PLOŠČADI

SISTEM ZA
GRADNJO
STAVB

STOPNICE

REF.
OBJEKTI

»T« NOSILCI "T" BEAMS

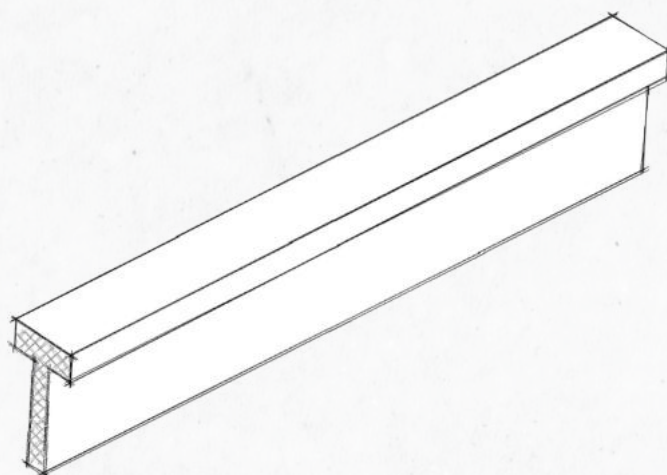

»T« nosilci so lahko prednapeti ali klasično armirani. Kvaliteta betona, ki se uporablja, je $C \geq 30/37$ v odvisnosti od statičnega izračuna. Dimenzije prečnega prereza so podane tabelarno in so odvisne od razpona ter vplivne površine. Nalegajo se na vrhe stebrov ali konzolne elemente stebrov v primeru naklona.

"T" beams are prestressed or classically reinforced beams. Concrete class $C \geq 30 / 37$ depending on the static calculation. The cross-sectional dimensions are given in the table below and depend on static calculation (ranges and corresponding surfaces).

They lay down at the top of the columns or the console column elements when there is denivelation.





»T« nosilec 60 (70, 80, 90, 100) / "T" beam 60 (70, 80, 90, 100)

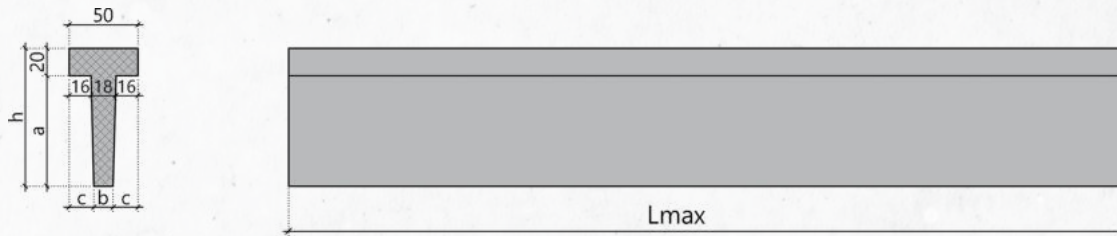

Tipi nosilcev – geometrijske lastnosti
 Type of beam - geometric characteristics

	dolžina / length (cm)
a	40, 50, 60, 70, 80
b	16, 15, 14
c	17, 17.5, 18
h	60, 80, 100
L max	700, 1000, 1200

»T« nosilec 120 / "T" beam 120

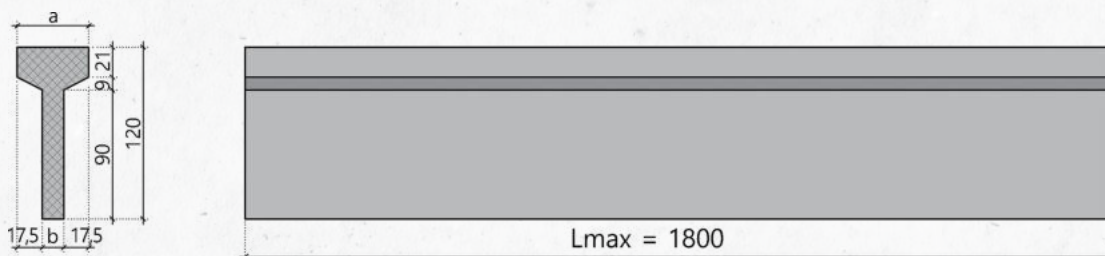

Tipi nosilcev – geometrijske lastnosti
 Type of beam - geometric characteristics

	dolžina / length (cm)
a	50 (55)
h	15 (20)



O NAS

TEMELJNE
ČAŠE

STEBRI

MEDETAŽNI
NOSILCIVOTLE
PLOŠČETT
PLOŠČEŽERJAVNE
PROGEGLAVNI
NOSILCI

GREĐICE

VEČNAMENSKE
PRAVOKOTNE
GREĐEFASADNI
PANELINAKLADALNE
PLOŠČADISISTEM ZA
GRADNJO
STAVB

STOPNICE

REF.
OBJEKTI

Gredice

Purlins

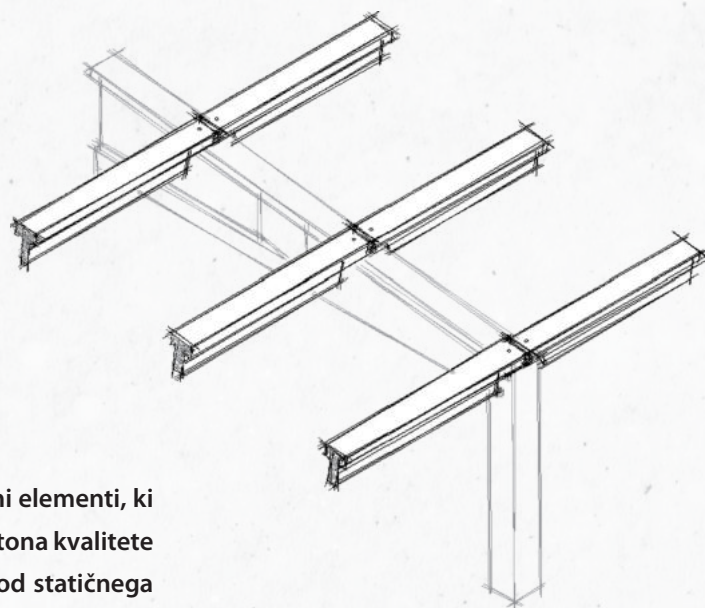

Sekundarni nosilci so prednapeti ali klasično armirani elementi, ki predstavljajo strešno konstrukcijo. Izdelujejo se iz betona kvalitete $C \geq 30/37$ in različnega tipa napenjanja v odvisnosti od statičnega izračuna. Dimenzije prečnega prereza so podane tabelarno in so odvisne od razpona ter vplivne površine. Sekundarni strešni nosilci nalegajo na glavne nosilce strešne konstrukcije.

Purlins are prestressed or classically reinforced. They are used as secondary beams for roof structures. Concrete class is $C \geq 30 / 37$ and there are different types of weights depending on the static calculation. The cross-sectional dimensions are given in the table below and depend on static calculation (ranges and corresponding surfaces). They will be located on the main supports of the roof structure.

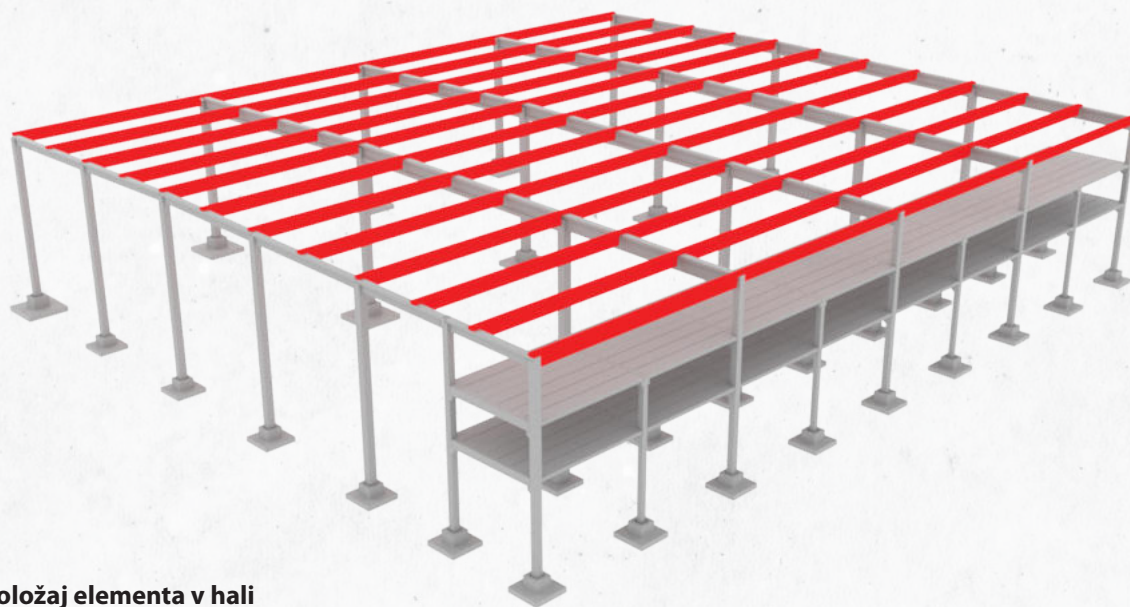

Položaj elementa v hali
Position of element in hall

Sn45 - trapezni
Sn45 - trapezoidal

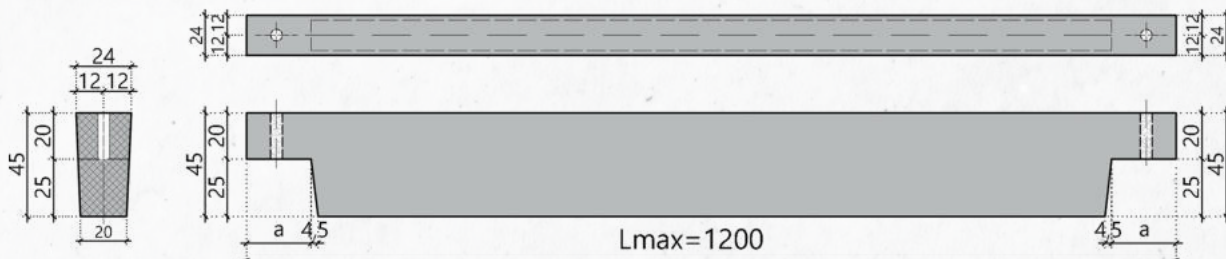

Tipi gredic – geometrijske lastnosti
Type of purlins - geometric characteristics

	dolžina / lenght (cm)
a	28 (55)
b	15 (20)
c	30 (25)

Sn60
Sn60

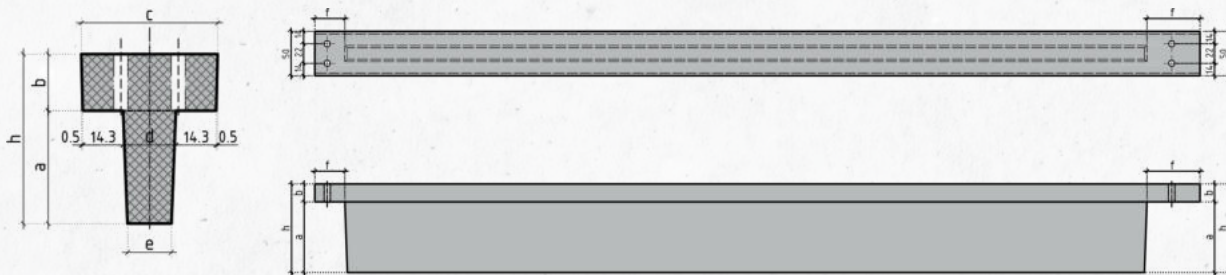

Tipi gredic – geometrijske lastnosti
Type of purlins - geometric characteristics

	dolžina / lenght (cm)
a	40 (45)
b	20 (15)
c	48.4 (52.4)
d	18.8 (22.8)
e	16 (20)
f	25, 34, 49, 60
h	=(a+b)



Sn70

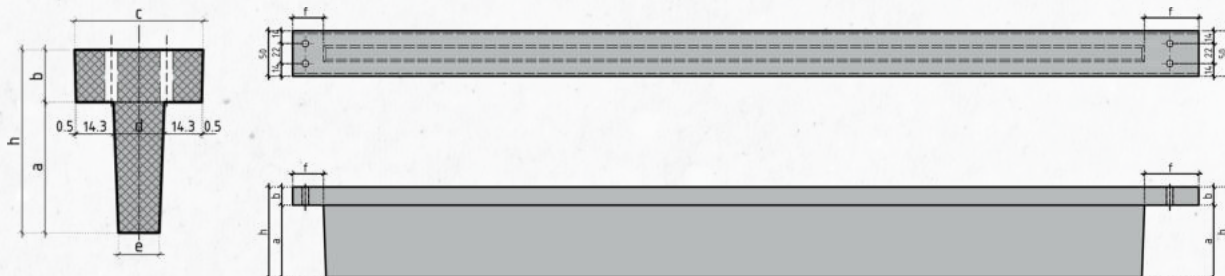

Tipi gredic – geometrijske lastnosti
Type of purlins - geometric characteristics

	dolžina / lenght (cm)
a	50
b	20
c	49.2 (53.2)
d	19.6 (23.6)
e	16 (20)
f	25, 34, 49, 60
h	=(a+b)

Sn80

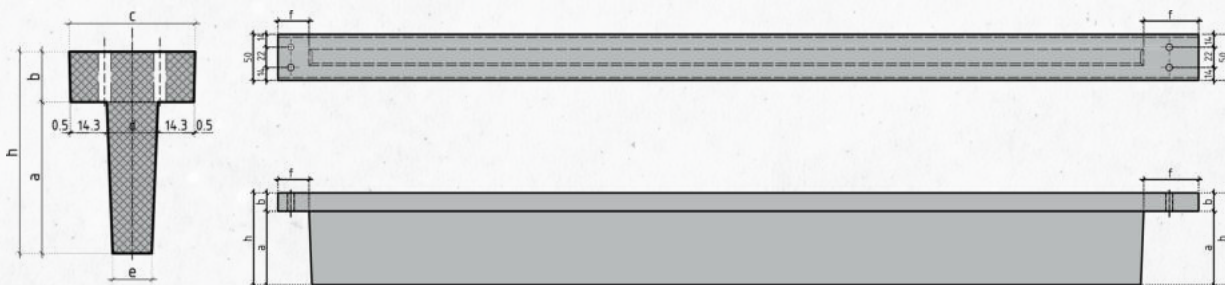

Tipi gredic – geometrijske lastnosti
Type of purlins - geometric characteristics

	dolžina / lenght (cm)
a	60
b	20
c	50 (54)
d	20.4 (24.4)
e	16 (20)
f	25, 34, 49, 60
h	=(a+b)



Sn90

Sn90

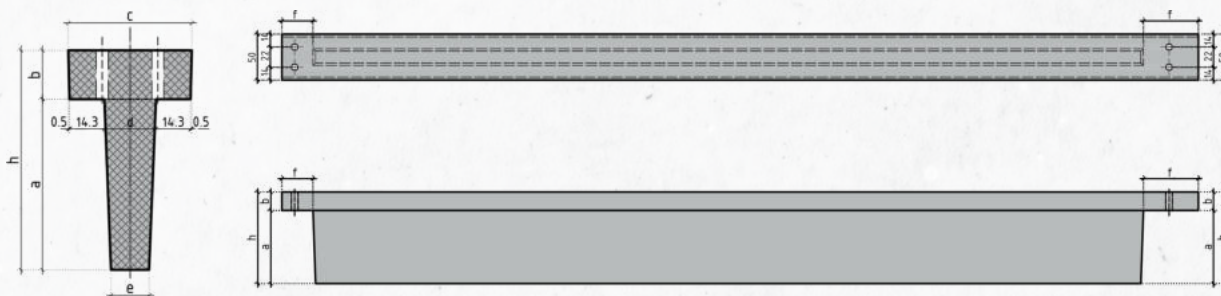

Tipi gredic – geometrijske lastnosti
 Type of purlins - geometric characteristics

	dolžina / length (cm)
a	70
b	20
c	50.8 (54.8)
d	21.2 (25.2)
e	16 (20)
f	25, 34, 49, 60
h	=(a+b)

Sn120

Sn120

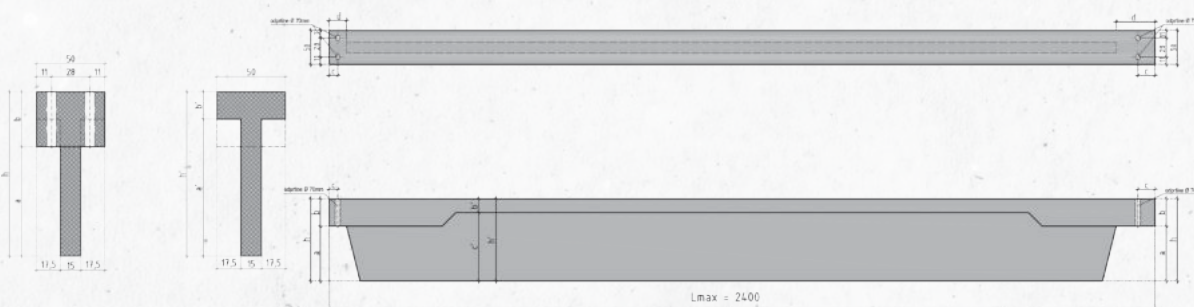

Tipi gredic – geometrijske lastnosti
 Type of purlins - geometric characteristics

	dolžina / length (cm)
a	80
a'	100
b	40
b'	20
c	13, 25
d	25, 55



O NAS

TEMELJNE
ČAŠE

STEBRI

MEDETAŽNI
NOSILCI

VOTLE
PLOŠČE

TT
PLOŠČE

ŽERJAVNE
PROGE

GLAVNI
NOSILCI

GREDICE

VEČNAMENSKE
PRAVOKOTNE
GREDE

FASADNI
PANELI

NAKLADALNE
PLOŠČADI

SISTEM ZA
GRADNJO
STAVB

STOPNICE

REF.
OBJEKTI





Za pokrivanje objektov, kot so hale, imamo dve rešitvi – strešne panele in sestavljene strehe (sistem sestavljenih streh). Strešni paneli se uporabljajo pri objektih, kjer so strešne ravnine z večjim naklonom (min. 5-odstotni naklon). V tem primeru je razpored gredic gostejši. Sestavljene strehe uporabljamo za strehe z manjšim naklonom (min. 1,5 % padca, največkrat za strehe s 3 %) in kjer so gredice redkeje razporejene.

To cover our halls, we use roof panels and a system of tiled roofs. Roof panels are used in objects where roof tiles are with a higher fall (min 5% fall) and the purlins are densely distributed, while we use system of tiled roofs for less falls (min. 1,5% falls, and most often for 3% fall) and the purlins are placed rarely.

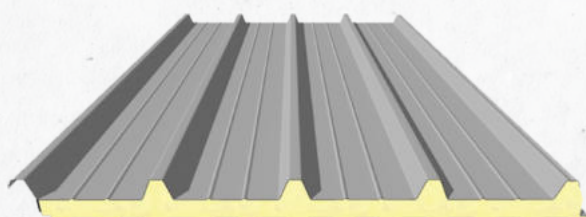

Videz strešnih panelov
Representation of roof panel

Videz sestavljene strehe
Representation of a system of tiled roof

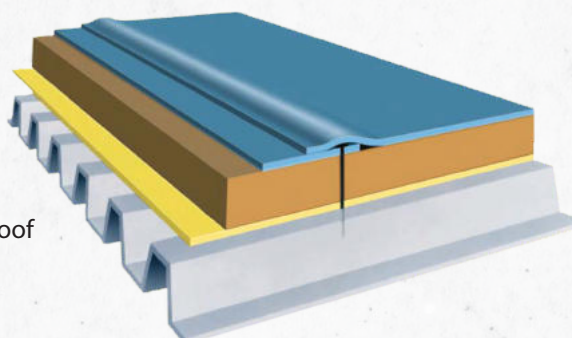

ABOUT
US

FOUNDATION
CUPS

COLUMNS

FLOOR
BEAMS

HOLLOW-
CORE
SLABS

DOUBLE
TT
SLABS

CRANE
GIRDERS

MAIN
BEAMS

PURLINS

MULTIPURPOSE
RECTANGULAR
BEAMS

FACADE
PANELS

LOADING
DOCKS

SYSTEM FOR
RESIDENTIAL
BUILDING

STAIRS

REF.
OBJECTS



REF. OBJEKTI	STOPNICE	SISTEM ZA GRADNJO STAVB	NAKLADALNE PLOŠČADI	FASADNI PANELI	VEČNAMENSKE PRAVOKOTNE GREDE	GREDE	GLAVNI NOSILCI	ŽERJAVNE PROGE	TT PLOŠČE	VOTLE PLOŠČE	MEDETAŽNI NOSILCI	STEBRI	TEMELJNE ČAŠE	O NAS
--------------	----------	-------------------------	---------------------	----------------	------------------------------	-------	----------------	----------------	-----------	--------------	-------------------	--------	---------------	-------

Večnamenske pravokotne grede

Multi-purpose rectangular beams

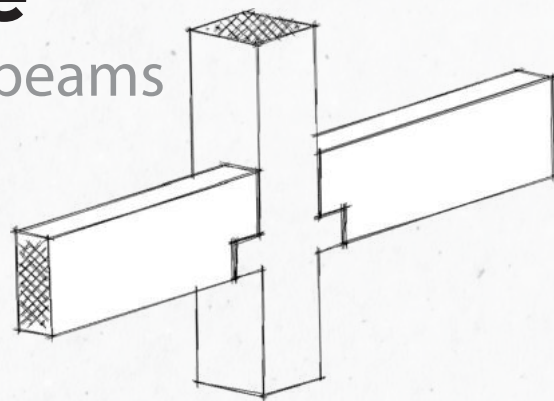

Večnamenske pravokotne grede so prefabricirani elementi, pravokotnega prečnega prereza in različnih dolžin, narejeni iz betona kvalitete $C \geq 30/37$ v odvisnosti od statičnega izračuna. Dimenzije so podane tabelarno. Pojavljajo se v obliki temeljnih in obodnih gred za fasadno konstrukcijo.

Purlins are prestressed or classically reinforced. They are used as secondary beams for roof structures. Concrete class is $C \geq 30 / 37$ and there are different types of weights depending on the static calculation. The cross-sectional dimensions are given in the table below and depend on static calculation (ranges and corresponding surfaces). They will be located on the main supports of the roof structure.

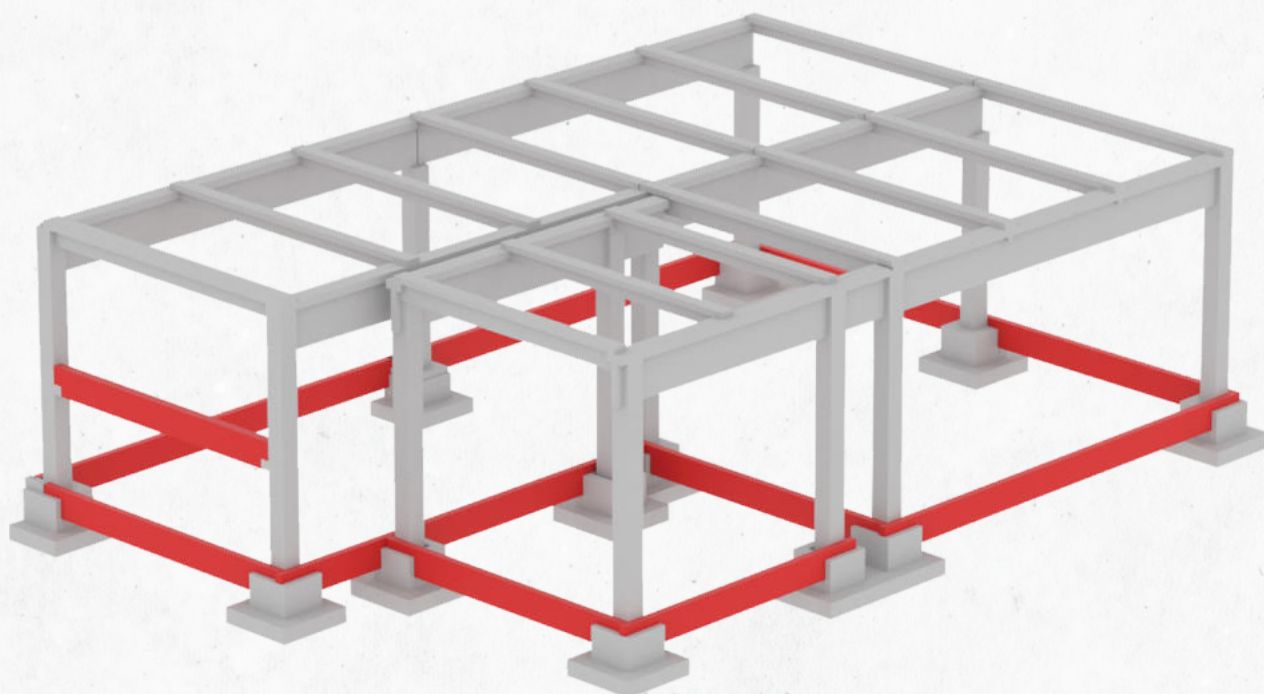

Položaj elementa v hali
Position of element in hall

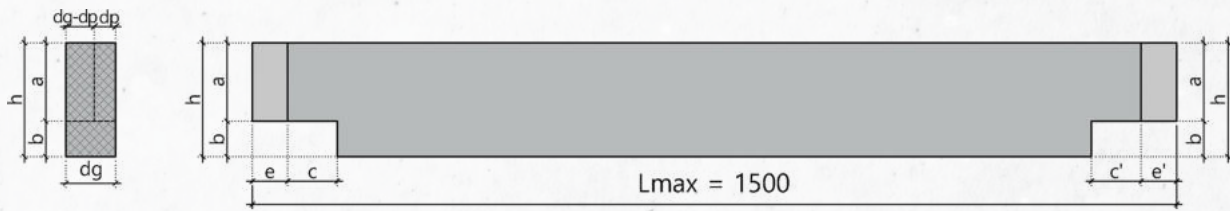

Tipi gred – geometrijske lastnosti
Type of beams - geometric characteristics

	dolžina / lenght (cm)
a	= (h-b)
b	20-40
h	50-100
dg	20-40
dp	dg-5
c, c'	0-40
e, e'	0-83

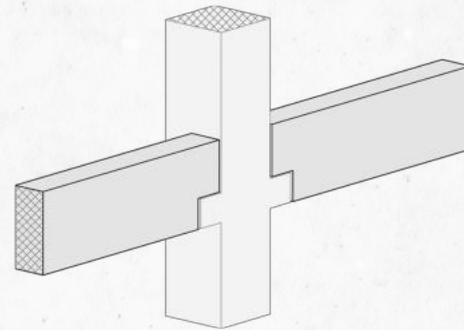

Temeljne grede
Base beams

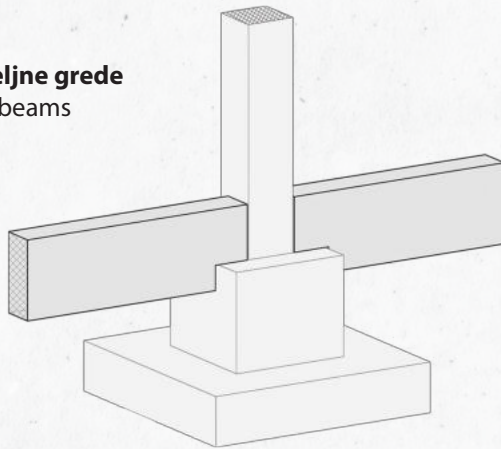

Fasadne grede
Facade beams

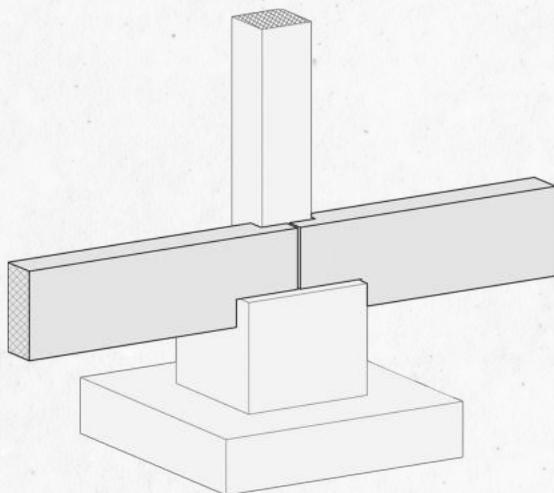
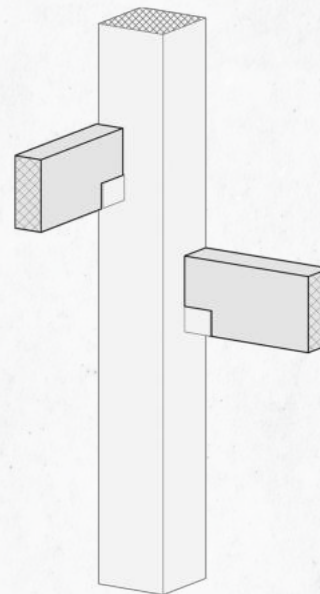

- ABOUT US
- FOUNDATION CUPS
- COLUMNS
- FLOOR BEAMS
- HOLLOW-CORE SLABS
- DOUBLE-T SLABS
- CRANE GIRDERS
- MAIN BEAMS
- PURLINS
- MULTIPURPOSE RECTANGULAR BEAMS
- FACADE PANELS
- LOADING DOCKS
- SYSTEM FOR RESIDENTIAL BUILDING
- STAIRS
- REF. OBJECTS



- O NAS
- TEMELJNE ČAŠE
- STEBRI
- MEDETAŽNI NOSILCI
- VOTLE PLOŠČE
- TT PLOŠČE
- ŽERJAVNE PROGE
- GLAVNI NOSILCI
- GREDICE
- VEČNAMENSKE PRAVOKOTNE GREDE
- FASADNI PANELI
- NAKLADALNE PLOŠČADI
- SISTEM ZA GRADNJO STAVB
- STOPNICE
- REF. OBJEKTI

Fasadni paneli

Facade panels

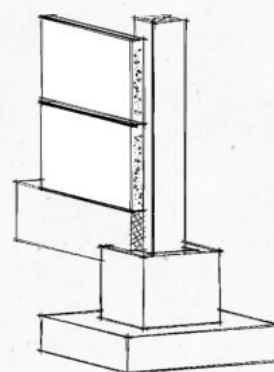

Prefabricirani betonski paneli se uporabljajo pri gradnji zunanjih, pregradnih in parapetnih zidov (v kombinaciji s sendvič paneli). Montirajo se horizontalno, vertikalno in v kombinaciji. Izdelujejo se lahko z izolacijo ali brez nje. Prva vrsta panelov nalega na vrhove temeljnih čaš, lahko se montirajo z zunanje strani, notranje ali med stebri. Koefficient toplotne prevodnosti λ zunanjih zidov doseže vrednosti tudi do $0,28 \text{ W/m}^2\text{K}$. Tesnjenje horizontalnih in vertikalnih spojev se zagotavlja z uporabo trajno elastičnih tesnilnih mas. Obešanje panelov na stebre se izvede po sistemu »Halfen«. Posamezni elementi sistema se vgradijo v panele in stebre že v fazi proizvodnje. Fasadni elementi se proizvajajo kot polni ali z odprtiniami za okna in vrata. Končna obdelava je lahko naravni beton, barvani beton ali obdelava površine s kulirjem, tudi s ščetkanim.

Prefabricated concrete panels are used in the manufacture of exterior, partition and parapet walls (in combination with sandwich panels). Mounted horizontally, vertically and in combination. They are made with and without isolation. The first row of the panels relies on the tops of the pocket foundations, and can be mounted on the outside, inside or between the columns. The thermal conductivity coefficient λ of the outer walls reaches a value of up to $0.28 \text{ W/m}^2\text{K}$. The sealing of horizontal and vertical joints is ensured by the use of elastic sealing mass. The hanging of the panel for columns is done via "Halfen" which is installed in panels and columns at the production stage. Facade elements are manufactured full or with openings for windows and doors. Finishing can be natural concrete, colored concrete and surface treatment in the "kulir", also brushed.

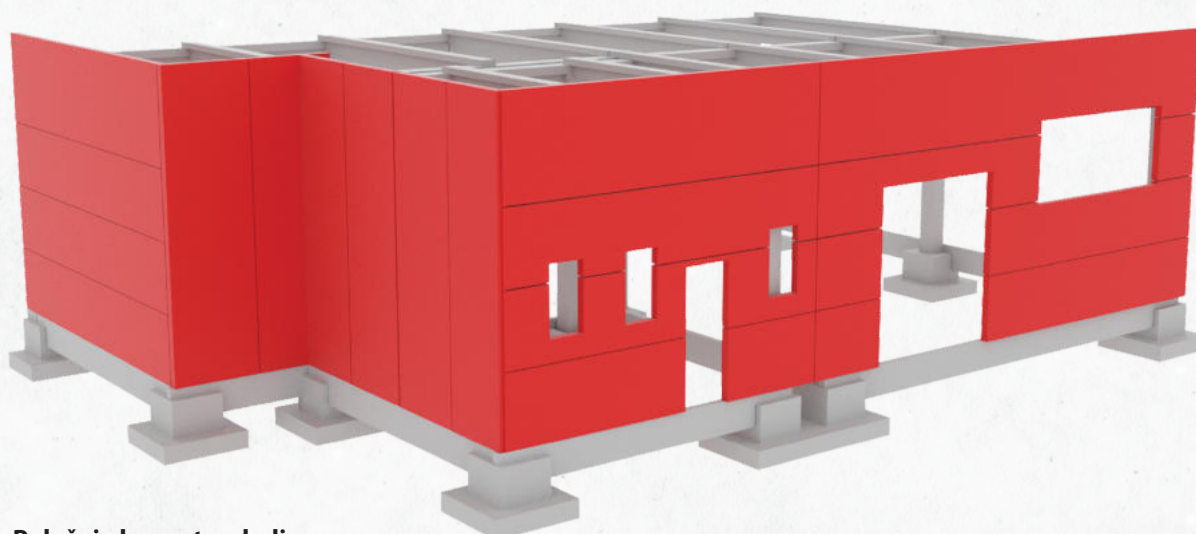

Položaj elementa v hali
Position of element in hall



Max. dimenzije
Max. dimensions

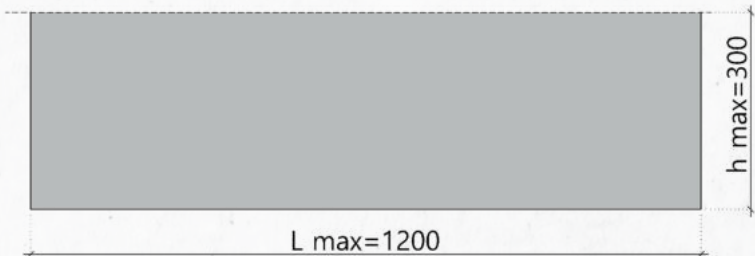

Detajl povezave betona in termoizolacije
Details of the connection between concrete and thermal insulation

Sendvič paneli (termo paneli)
Sandwich panels (thermo panels)

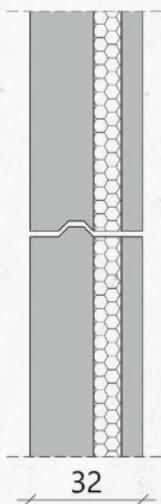

Enoslojni paneli
Single panels

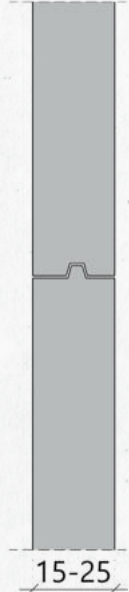

Možna izvedba s sprostivijo ali brez nje
Possible workmanship with and without relief

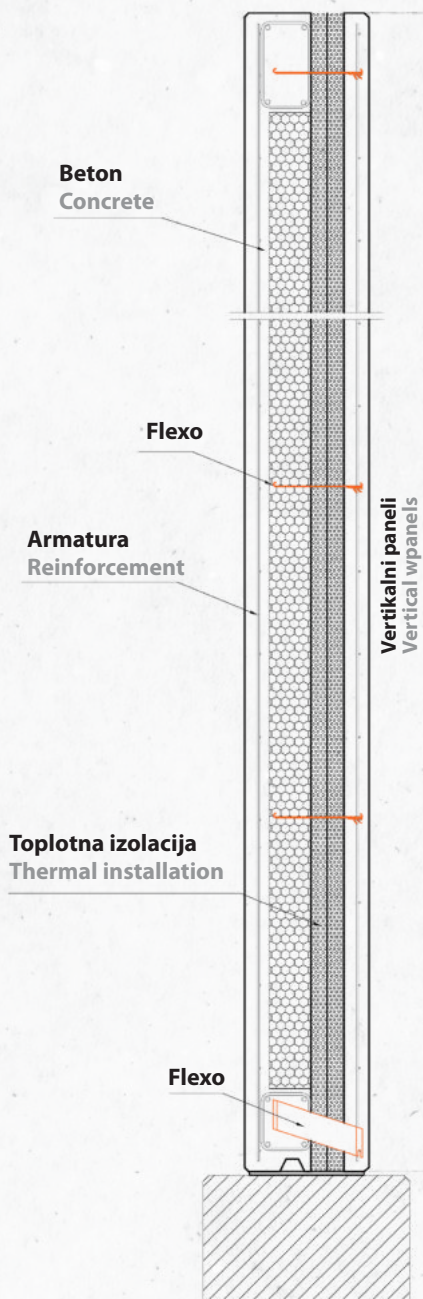
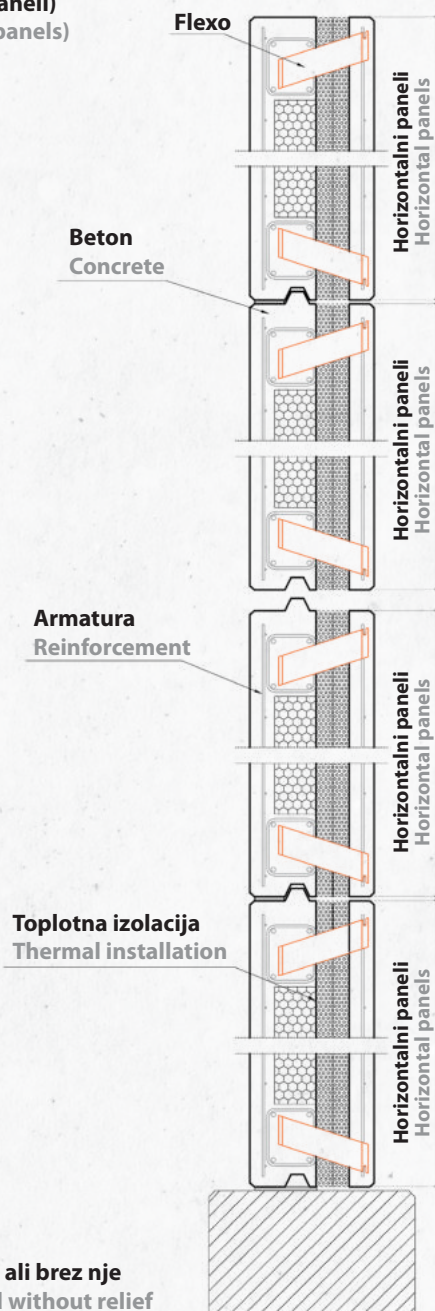

- ABOUT US
- FOUNDATION CUPS
- COLUMNS
- FLOOR BEAMS
- HOLLOW-CORE SLABS
- DOUBLE TT SLABS
- CRANE GIRDERS
- MAIN BEAMS
- PURLINS
- MULTIPURPOSE RECTANGULAR BEAMS
- FACADE PANELS
- LOADING DOCKS
- SYSTEM FOR RESIDENTIAL BUILDING
- STAIRS
- REF. OBJECTS



O NAS

TEMELJNE ČAŠE

STEBRI

MEDETAŽNI NOSILCI

VOTLE PLOŠČE

TT PLOŠČE

ŽERJAVNE PROGE

GLAVNI NOSILCI

GREDECE

VEČNAMENSKE PRAVOKOTNE GREDE

FASADNI PANELI

NAKLADALNE PLOŠČADI

SISTEM ZA GRADNJO STAVB

STOPNICE

REF. OBJEKTI

Detajl povezave stebra in fasadnega panela v tlorisu (skrita povezava)

Details of the connection between concrete and thermal insulation

Detajl povezave stebra in fasadnega panela v tlorisu (skrita povezava)
Connection between the column and the facade panel in the base (hidden connection)

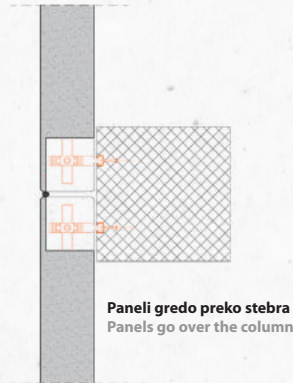

Prikaz povezave stebra in fasadnega panela v tlorisu (vidna povezava)
Connection between the column and the facade panel in the base (visible connection)



Prikaz povezave stebra in fasadnega panela v vzdolžnem prerezu (vidna povezava)
Connection between the column and the facade panel in the longitudinal section (visible connection)

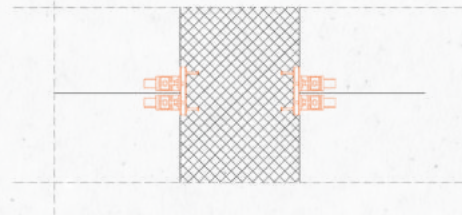

Prikaz povezave stebra in fasadnega panela v prečnem prerezu (vidna povezava)
Connection between the column and the facade panel in the cross-section (visible connection)

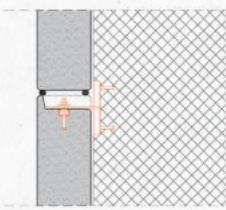

Prikaz povezave stebra in fasadnega panela v prečnem prerezu (skrita povezava)
Connection between the column and the facade panel in the cross-section (hidden connection)

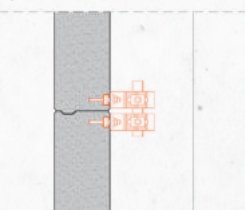

3D model

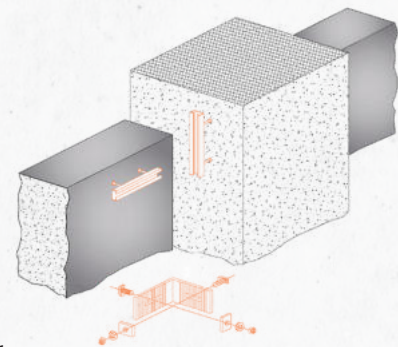

Detajl povezave dveh horizontalnih fasadnih AB panelov na vogalih objekta

Detail of the connection between the horizontal facade AB panel at the corners of the building

Prikaz vogalne povezave stebra in fasadnega panela v tlorisu s prizrezovanjem panela in brez (skrita povezava)
Angular connection of the column and the facade panels in basic with cutting panel under angle 45° and without cutting (hidden connection)

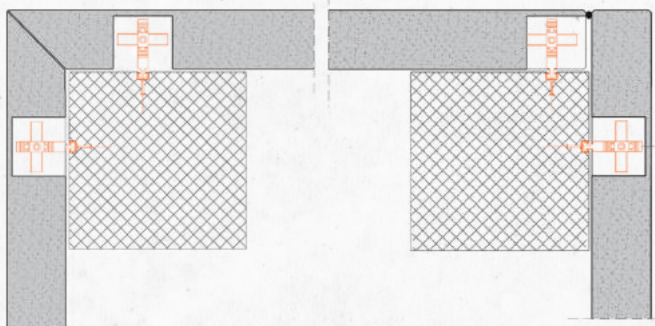

Prikaz vogalne povezave stebra in fasadnega panela v tlorisu (vidna povezava)
Angular connection of the column and the facade panel in the base (visible connection)

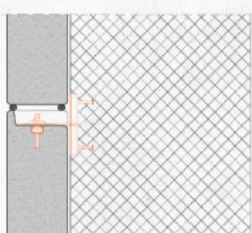
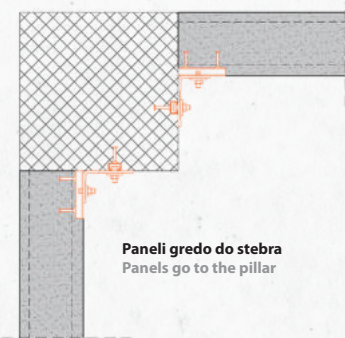

Prikaz vogalne povezave stebra in fasadnega panela v prečnem prerezu (skrita povezava)
Angular connection of the column and the facade panel in a lateral cross-section (hidden connection)

Prikaz vogalne povezave stebra in fasadnega panela v prečnem prerezu (vidna povezava)
Angular connection of the column and the facade panel in a lateral cross-section (visible connection)

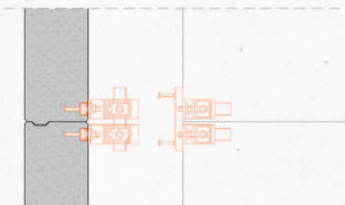

Detajl povezave horizontalnega fasadnega AB panela z nosilnim stebrom in temeljno grede
Detail of the connection between the horizontal facade AB panel with the supporting column and the pocket foundation

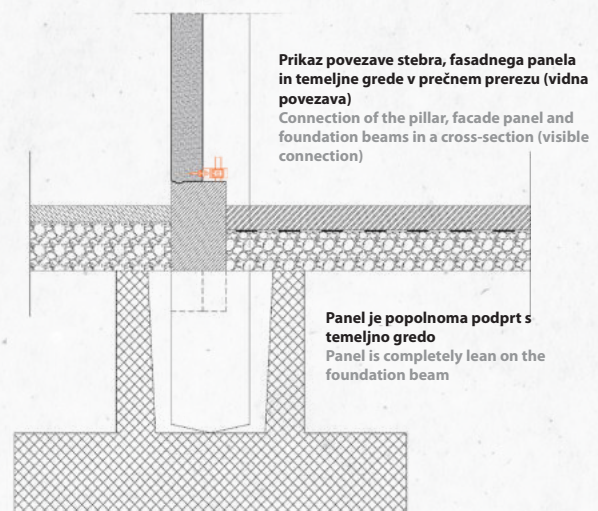
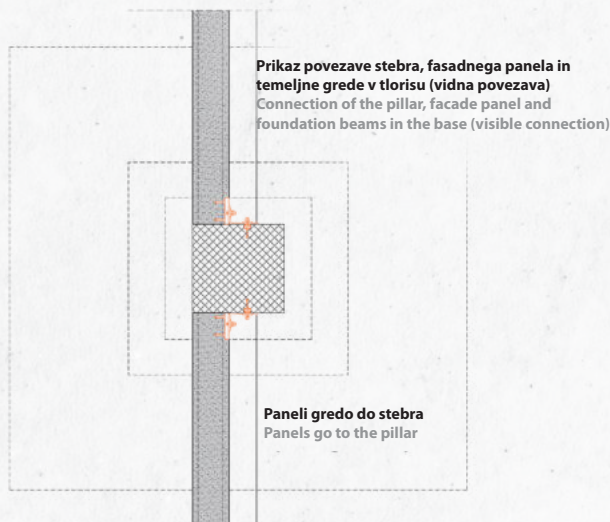
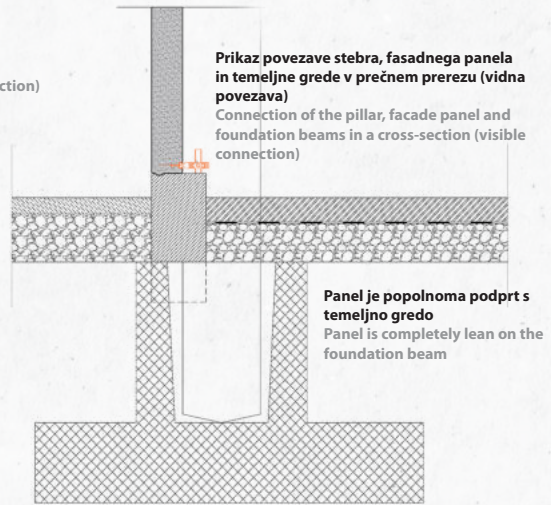
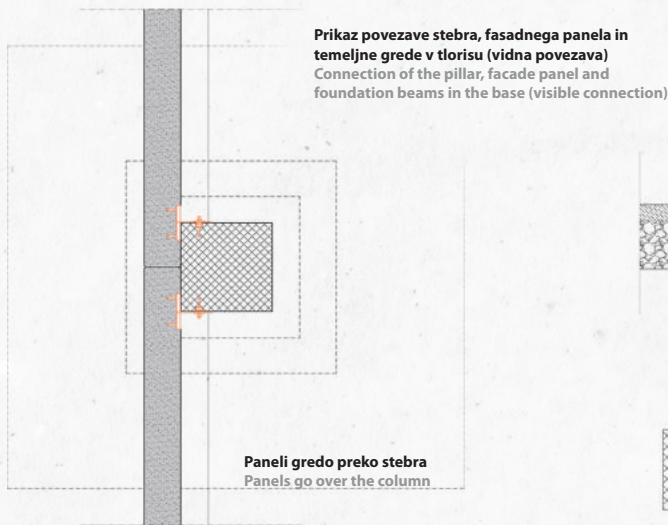
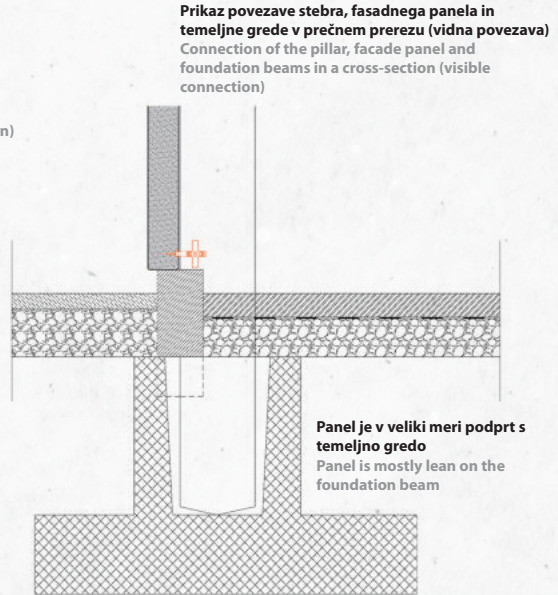
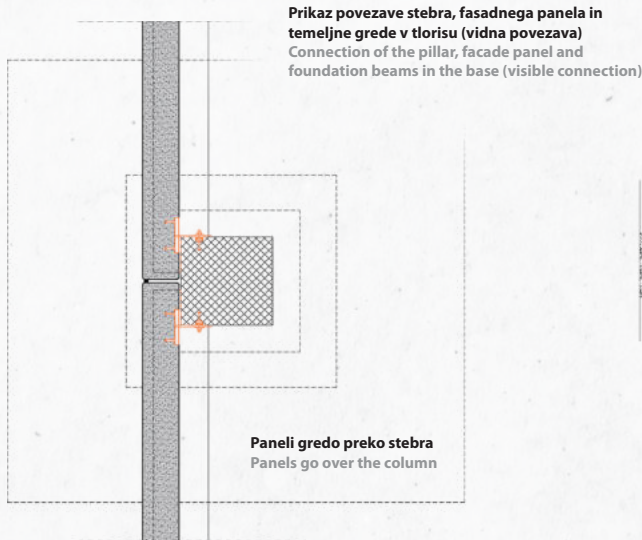

ABOUT US	FOUNDATION CUPS	COLUMNS	FLOOR BEAMS	HOLLOW-CORE SLABS	DOUBLE TT SLABS	CRANE GIRDERS	MAIN BEAMS	PURLINS	MULTIPURPOSE RECTANGULAR BEAMS	FACADE PANELS	LOADING DOCKS	SYSTEM FOR RESIDENTIAL BUILDING	STAIRS	REF. OBJECTS
----------	-----------------	---------	-------------	-------------------	-----------------	---------------	------------	---------	--------------------------------	----------------------	---------------	---------------------------------	--------	--------------



O NAS
 TEMELJNE ČAŠE
 STEBRI
 MEDETAŽNI NOSILCI
 VOTLE PLOŠČE
 TT PLOŠČE
 ŽERJAVNE PROGE
 GLAVNI NOSILCI
 GREĐICE
 VEČNAMENSKE PRAVOKOTNE GREDE
 FASADNI PANELI
 NAKLADALNE PLOŠČADI
 SISTEM ZA GRADNJO STAVB
 STOPNICE
 REF. OBJEKTI

Detajl povezave fasadnega AB panela in sekundarnega nosilca

Detail of the connection between the facade AB panel and the secondary beam

Prikaz povezave fasadnega panela in gredice v tlorisu
 Connection of the facade panel and the purlins in the base

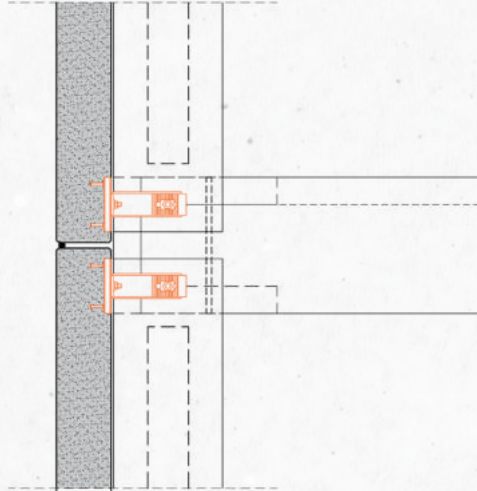

Prikaz povezave fasadnega panela in gredice v prerezu
 Connection of the facade panel and the purlins in the cross section

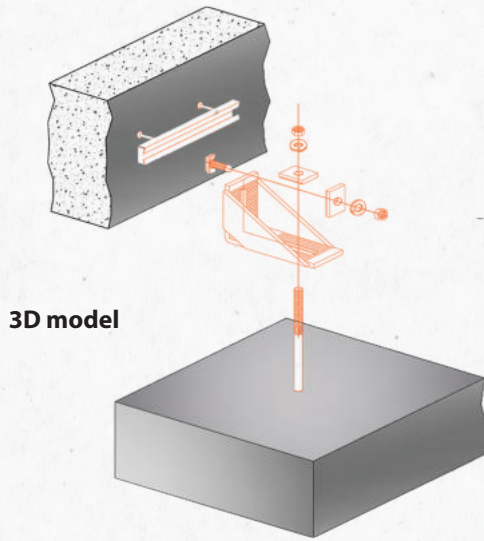
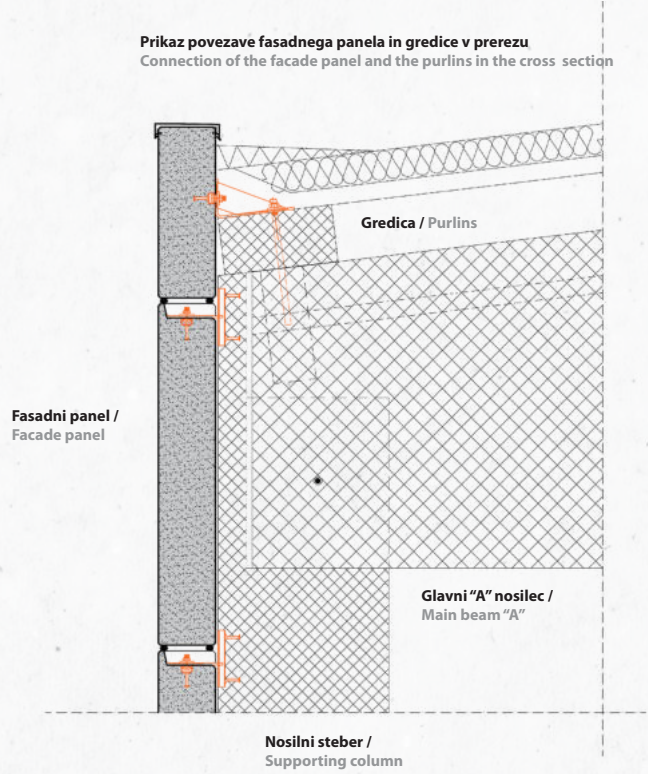

Detajl povezave dveh horizontalnih fasadnih AB panelov v delu fasade, kjer se pojavlja odprtina

Detail of the connection of the two horizontal facade AB panels in the part of the facade where the hole appears

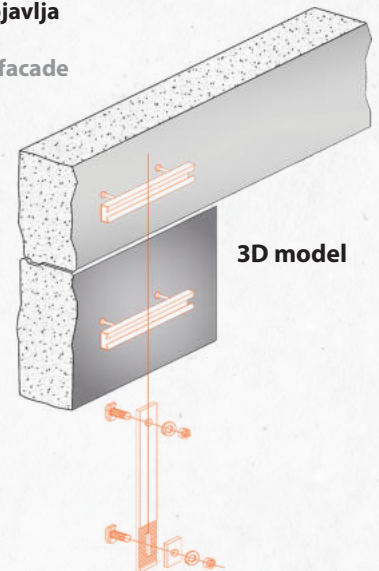
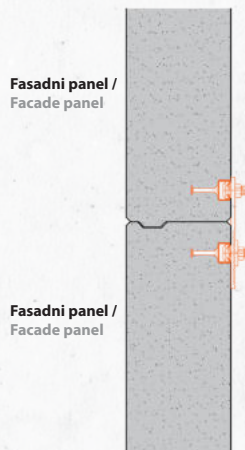
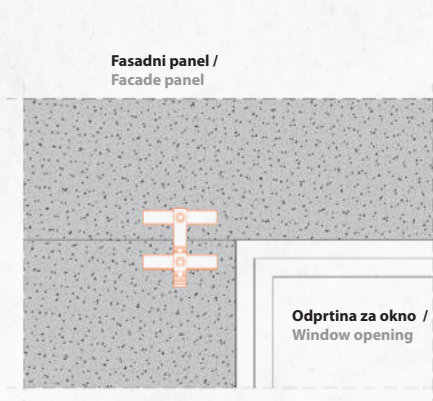



- ABOUT US
- FOUNDATION CUPS
- COLUMNS
- FLOOR BEAMS
- HOLLOW-CORE SLABS
- DOUBLE-TT SLABS
- CRANE GIRDERS
- MAIN BEAMS
- PURLINS
- MULTIPURPOSE RECTANGULAR BEAMS
- FACADE PANELS**
- LOADING DOCKS
- SYSTEM FOR RESIDENTIAL BUILDING
- REF. OBJECTS





REF. OBJEKTI
STOPNICE
SISTEM ZA GRADNJO STAVB
NAKLADALNE PLOŠČADI
FASADNI PANELI
VEČNAMENSKE PRAVOKOTNE GREDE
GREDE
GREDICE
GLAVNI NOSILCI
ŽERJAVNE PROGE
TT PLOŠČE
VOTLE PLOŠČE
MEDETAŽNI NOSILCI
STEBRI
TEMELJNE ČAŠE
O NAS

Nakladalne ploščadi

Loading docks

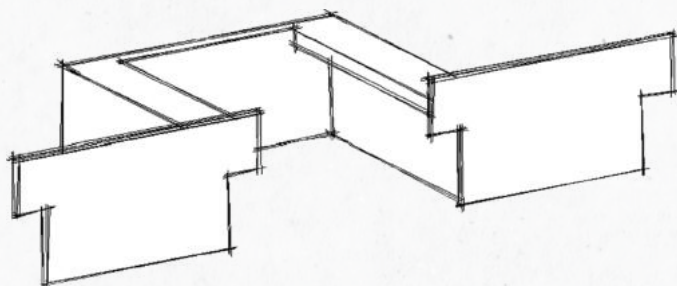

Nakladalne ploščadi so zasnovane tako, da so postavljene med skladišča in tovarnjake ali prikolice ter omogočajo hitro in neovirano gibanje viličarjev med nakladanjem in raztovarjanjem. Prefabricirani nakladalni kanali so zasnovani, proizvedeni in nameščeni skladno z zahtevami stranke. Naše nakladalne ploščadi odlikuje visoka kakovost končne obdelave, natančnost in hitrost montaže. Sistemi za nakladalne ploščadi so sestavljeni iz: sprednjih zidov »T« oblike, zadnjih in stranskih podpornih zidov, mostne plošče in toplotno izolacijskih panelov.

The loading docks are designed to be positioned between the warehouse and the truck or trailer and ensure the fast and undisturbed movement of forklifts during loading and unloading. Prefabricated loading channels are designed, manufactured and installed in accordance with the requirements of the client. Our loading docks combines high quality finishing and precision with mounting speed. The frame of bearing for loading frames consist of: front walls of "T" shapes, rear and end support walls, bridges plate and thermo-insulated panels.

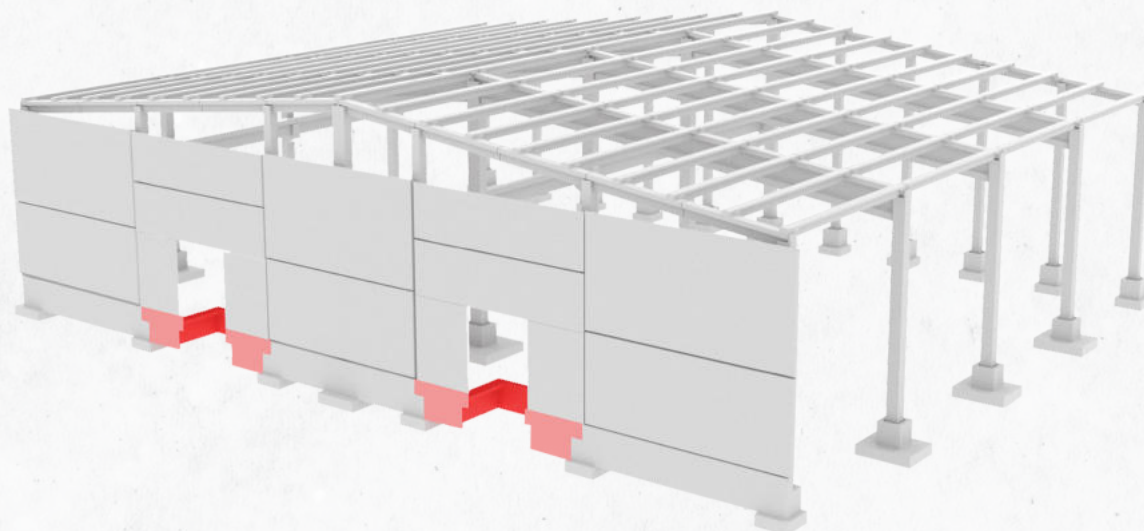

Položaj elementa v hali
Position of element in hall

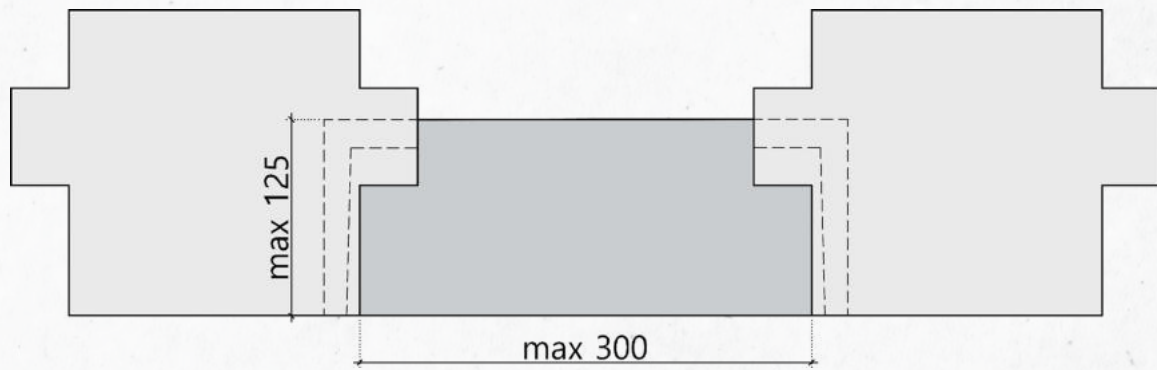

TIP 1 / TYPE 1

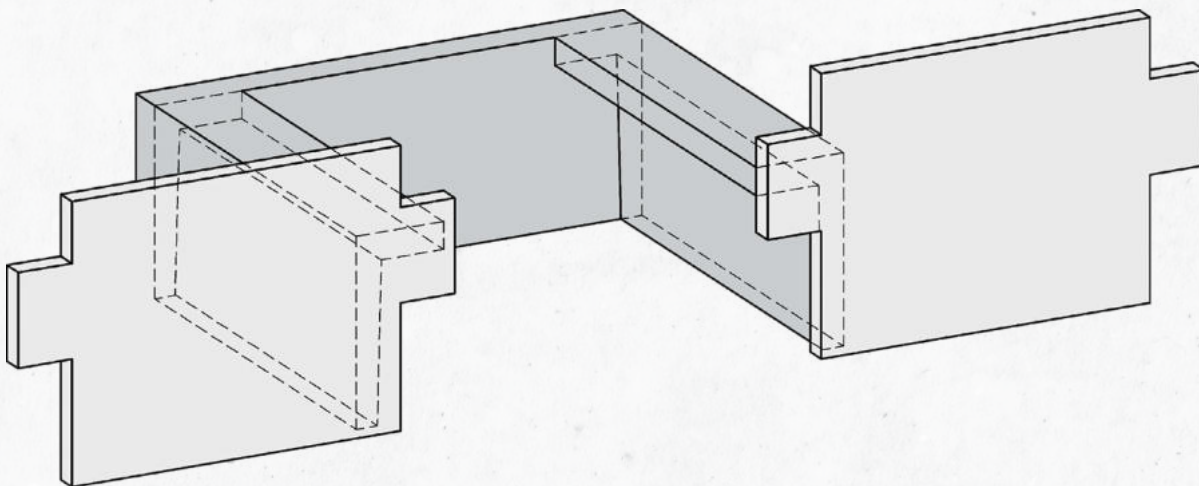

TIP 2 / TYPE 2

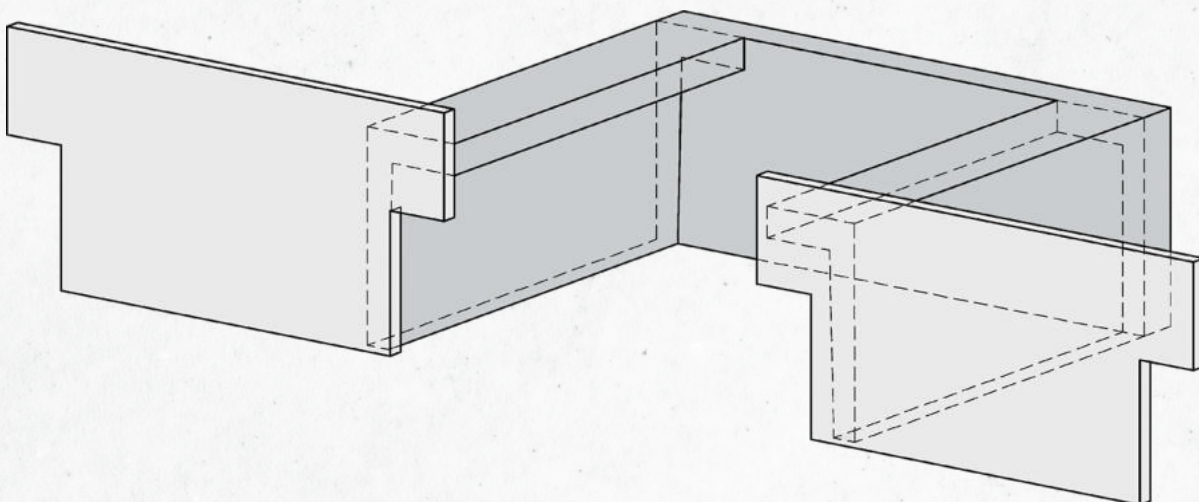

ABOUT US	FOUNDATION CUPS	COLUMNS	FLOOR BEAMS	HOLLOW-CORE SLABS	DOUBLE TT SLABS	CRANE GIRDERS	MAIN BEAMS	PURLINS	MULTIPURPOSE RECTANGULAR BEAMS	FACADE PANELS	LOADING DOCKS	SYSTEM FOR RESIDENTIAL BUILDING	REF. OBJECTS
----------	-----------------	---------	-------------	-------------------	-----------------	---------------	------------	---------	--------------------------------	---------------	---------------	---------------------------------	--------------



O NAS

TEMELJNE ČAŠE

STEBRI

MEDETAŽNI NOSILCI

VOTLE PLOŠČE

TT PLOŠČE

ŽERJAVNE PROGE

GLAVNI NOSILCI

GREDECE

VEČNAMENSKE PRAVOKOTNE GREDE

FASADNI PANELI

NAKLADALNE PLOŠČADI

SISTEM ZA GRADNJO STAVB

STOPNICE

REF. OBJEKTI

Sistem za gradnjo stavb

System for residential building

Dvojni zidovi

Twin walls

Prefabricirani dvojni betonski zidovi predstavljajo konstrukcijske nosilne zidove, ki so sestavljeni iz končanih betonskih plošč debeline $d = 5-6$ cm in so povezani z rešetkastimi nosilci. Prefabricirani zidni elementi se montirajo na gradbišču, zalivajo z betonom na samem kraju in hkrati služijo kot opaž. Končni proizvod je monolitni zid z gladko površino, ki je pripravljen na končno obdelavo – glajenje in barvanje z obeh strani. Dimenzije zidnih panelov se prilagajajo projektu, medtem ko se v zidne elemente vgrajujejo okvirji za vrata in okna, revizijske omarice za elektroinstalacije in ostali instalacijski preboji. Lahko se izdelajo z ali brez izolacije.

Precast Concrete Twin Walls are constructive supporting walls, consisting of two finished concrete slabs thickness $d=5-6$ cm and connected with a steel lattice girders. Prefabricated wall elements are mounted on the site and filled with in-situ concrete on site, perform as formwork. The final wall is a solid concrete wall with a high quality paint-ready finish on both sides. The dimensions of the wall panels are adapted to the project, while the door frame and window frames, boxes for electrical installations and other installation boxes are installed in the wall elements. They can be made with and without isolation.

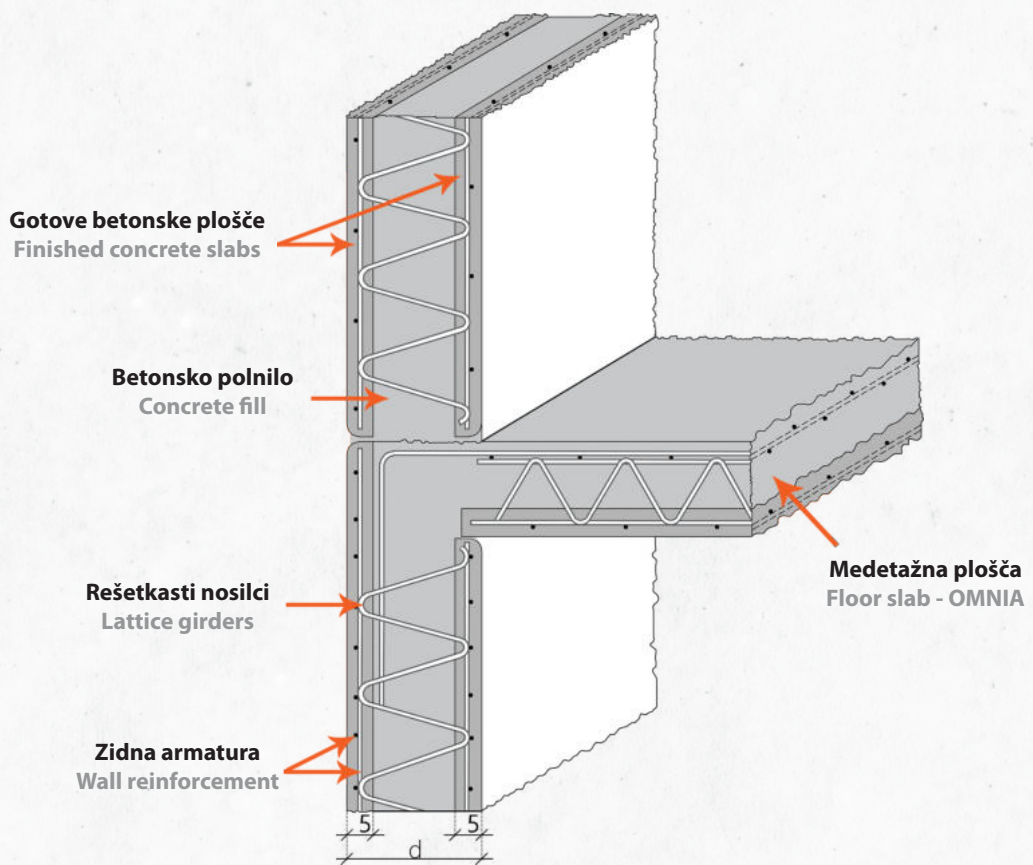



Ker ima vsako načrtovanje svoje specifične lastnosti, to pomeni, da je vsak objekt specifičen na svoj način. Naši dvojni zidovi se proizvajajo skladno z zahtevami projekta. Ne samo, da ima vsak zid svoje edinstvene dimenzije, odprtine za vrata in okna, temveč tudi vgradni deli za končno obdelavo se lahko naredijo na samem kraju. Takšen način gradnje objekta je zelo prilagodljiv in hiter. Na sliki je prikazan primer.

Because each design has its own specific properties - it is specific in its own way, our double walls are produced in accordance with the requirements of the project. Not only does each wall have its own unique dimensions, door and window openings, but the built-in parts for finishing can also be left on site. This form of building an object is very flexible and fast. The picture shows one of the examples.

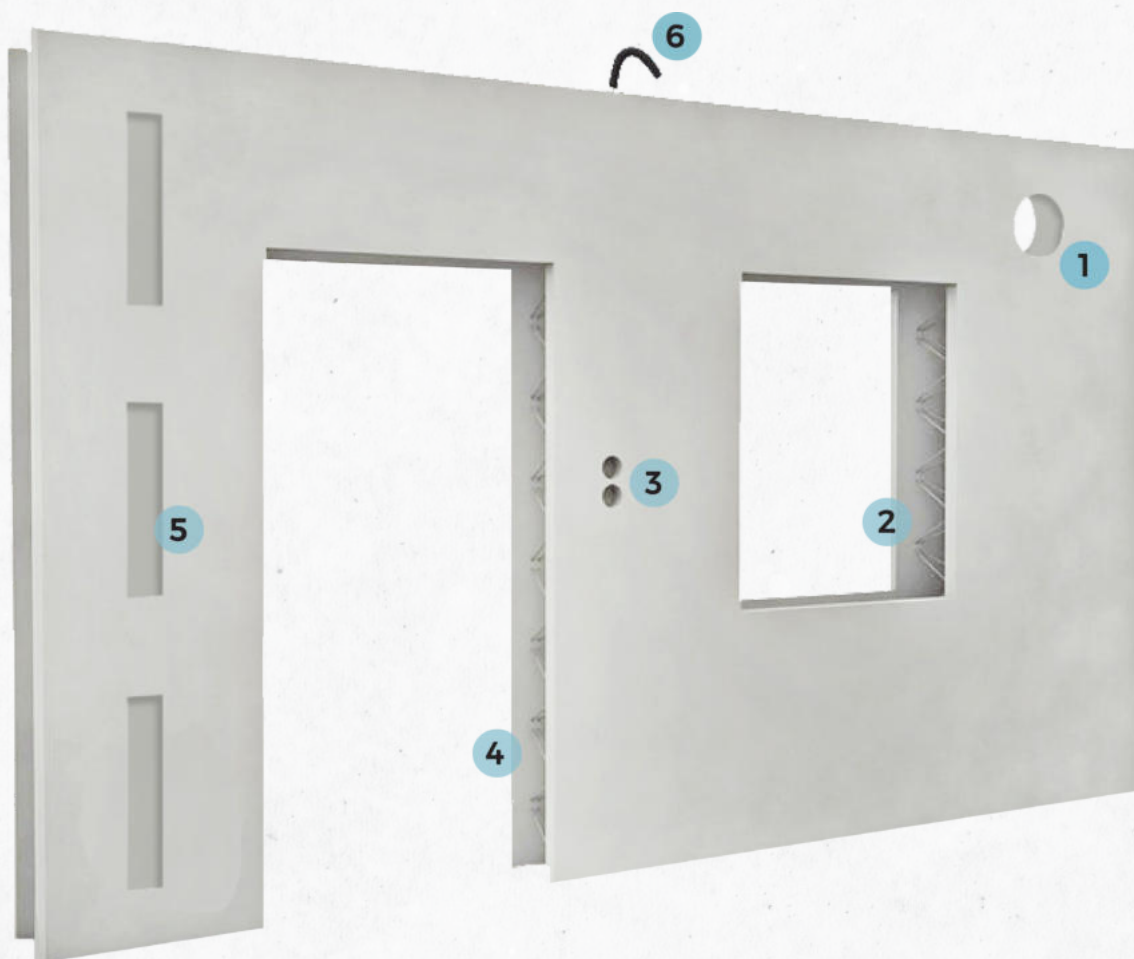

- | | |
|--|---|
| <p>1 Odprtine, preboji
Openings, passageways</p> | <p>4 Odprtina predvidena za vrata
Door frames</p> |
| <p>2 Odprtine za okna
Window openings</p> | <p>5 Ojačitev za spoje zalite z betonom na licu mesta
Reinforcement for joints with concrete poured on-site</p> |
| <p>3 Električni priključki
Electrical fittings openings</p> | <p>6 Cev za vertikalno napajanje električnih instalacij
Pipe for the vertical powering of electrical installations</p> |



Transport Transporation

Dvigalom in transportnim vozilom mora biti omogočen neoviran dostop do lokacije objekta. Upoštevati je treba možne ovire na ulici, ostrino ovinkov, parkirana vozila itd. Transportna vozila so dolga 8 m. Vertikalni transport z zabojniki se uporablja za zidove, katerih maksimalna višina je 2,8 m. V primeru zidov, ki so višji od 2,8 m, se ti prevažajo v horizontalni legi, pri čemer mora biti naležna površina na transportnem vozilu primerno ravna in toga. Kabli za dvigovanje morajo biti dovolj dolgi, tako da je naklonski kot med elementom in kablom najmanj 60°.

It is necessary to allow the crane and deep loaders to have an undisturbed access to the location of the object. It is necessary to take into account the possible obstruction of the street, curvature of the curves, parked vehicles, etc. Transport vehicles have a length of up to 18m. Vertical transport with a container is used for walls with a maximum height of up to 2.8m. In the case of horizontal shipment, the base for supporting the element in the truck must be straight. This type of transport is used for walls higher than 2.80 m. The lifting cables must be sufficiently long and the angle formed between the element and the cable must be at least 60°



● Prednosti

- Proizvodnja v tovarni je neodvisna od vremenskih vplivov;
- Ni čakanja pri odstranjevanju opaža;
- Vgradni elementi, kot so okna, vrata, okviri od vrat, kanali za kable in električne omarice, se lahko predvidijo v tovarni;
- Še posebno gladke površine znotraj in zunaj;
- Dobra zvočna izolacija;
- Preprosto povezovanje talne plošče in stropa z armaturo v betonu.

● Gains

- Production at the factory independent of weather conditions
- There is no waiting for removal of the formwork
- Installation elements such as windows, doors, door frames, cable ducts and electrical they can be installed in the factory
- Particularly smooth surfaces inside and outside
- Good sound insulation
- Easy connection of floor slabs and ceilings with reinforcement in concrete

ABOUT
US

FOUNDATION
CUPS

COLUMNS

FLOOR
BEAMS

HOLLOW-
CORE
SLABS

DOUBLE
TT
SLABS

CRANE
RIDERS

MAIN
BEAMS

PURLINS

MULTIPURPOSE
RECTANGULAR
BEAMS

FACADE
PANELS

LOADING
DOCKS

SYSTEM FOR
RESIDENTIAL
BUILDING

STAIRS

REF.
OBJECTS



Omnia plošče

Omnia slabs

»Omnia« plošča je prefabricirana armiranobetonska plošča, ki se monolitizira na gradbišču. Debelina »omnia« plošče je 5–6 cm in vsebuje rešetkasti nosilec, ki ji zagotavlja togost in olajša namestitev zgornje mreže. Na gradbišču se postavlja armatura zgornje cone in preklopa, nato se betonira z betonom debeline od 16 do 20 cm. V »omnia« plošče se vgrajujejo razvodne omarice za elektroinstalacije in pripravijo se vse potrebne odprtine ter preboji.

“Omnia” slabs are reinforced precast concrete slabs that are being monolithize on the site. The thickness of the omnia slab is 5-6 cm, with built-in reinforcement of the lower zone of the floor slab and lattice girders. On the construction site, the reinforcement of the upper zone and the overlap is installed, and then in-situ concrete is poured on-site to a full thickness of 16 to 20 cm. In the process of making the Omnia slab, it is necessary to take care of the architectural, static and installation requirements.

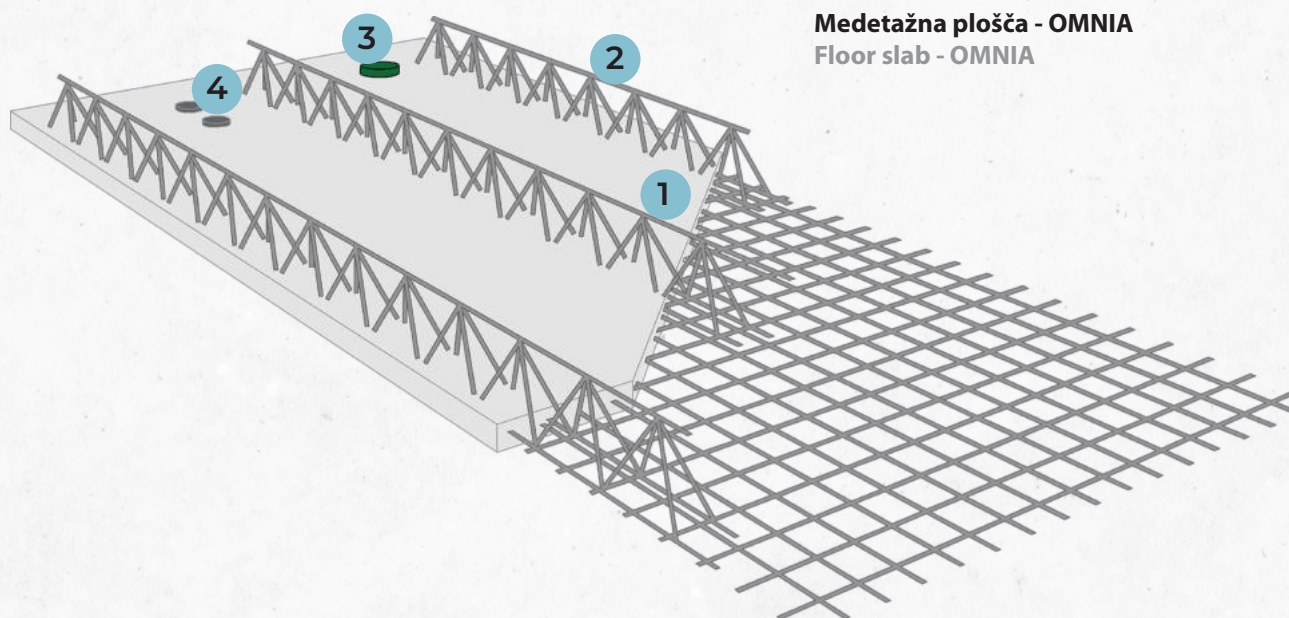

Medetažna plošča - OMNIA
Floor slab - OMNIA



- 1**
 - Armirana betonska plošča, ki je zelo fleksibilna;
 - Na voljo je križno armiranje, ki omogoča zmanjšanje debeline tal;
 - Odpornost proti požaru je 1 ura; s spremembo debeline plošče lahko tudi do 4 ur;
 - Končna izvedba tal ustreza najvišjim standardom glede zvočne izolacije;
 - Talne obloge iz rešetkastih plošč se lahko prilagajajo več vrstam objektov;
 - Lahko se uporabljajo skoraj z vsemi vrstami konstrukcij.

• Reinforced concrete slab that is completely flexible;

• Two-way design is available to reduce the thickness of the floor;

• 1 hour of fire resistance; Up to 4 hours can be achieved by changing the thickness of the panels;

• The final version of the floor meets the highest standards of sound regulations;

• Floor cladding from grid plates can correspond to most types of objects;

• Can be used with almost all types of constructions.
- 2**
 - Fleksibilnost rešetkaste konstrukcije se lahko uporablja za modifikacijo razporeda podpiranja
 - The flexibility of the lattice structure can be used to modify the support schedule.
- 3**
 - Vgrajena odprtina za mehanično ventilacijo
 - Built-in opening for mechanical ventilation
- 4**
 - Centrale škatle za električne vode
 - Central electrical conduit boxes



REF. OBJEKTI	SISTEM ZA GRADNJO STAVB	NAKLADALNE PLOŠČADI	FASADNI PANELI	VEČNAMENSKE PRAVOKOTNE GREDE	GREĐICE	GLAVNI NOSILCI	ŽERJAVNE PROGE	TT PLOŠČE	VOTLE PLOŠČE	MEDETAŽNI NOSILCI	STEBRI	TEMELJNE ČAŠE	O NAS
--------------	-------------------------	---------------------	----------------	------------------------------	---------	----------------	----------------	-----------	--------------	-------------------	--------	---------------	-------

Stopnice

Stairs

Prefabricirane betonske montažne stopnice, narejene iz armiranega betona, so ena od najboljših možnosti za odpravljanje težav, ki se pojavljajo pri klasični gradnji stopnic (prilagoditev števila stopnic, vzponov, pohodnih ploskev in širine stopnic).

Precast concrete precast staircase, made of reinforced concrete, is one of the best options for eliminating the problem of adjusting the number of steps, climb, stair treads and width of each.

Na voljo je kot / It is available as:

- 1 ena montažna enota, ki vsebuje celotno stopnišče, one mounting unit that contains a complete staircase,
- 2 ločeno prefabricirano stopnišče in podesti. separately pre-assembled stairs and landing.

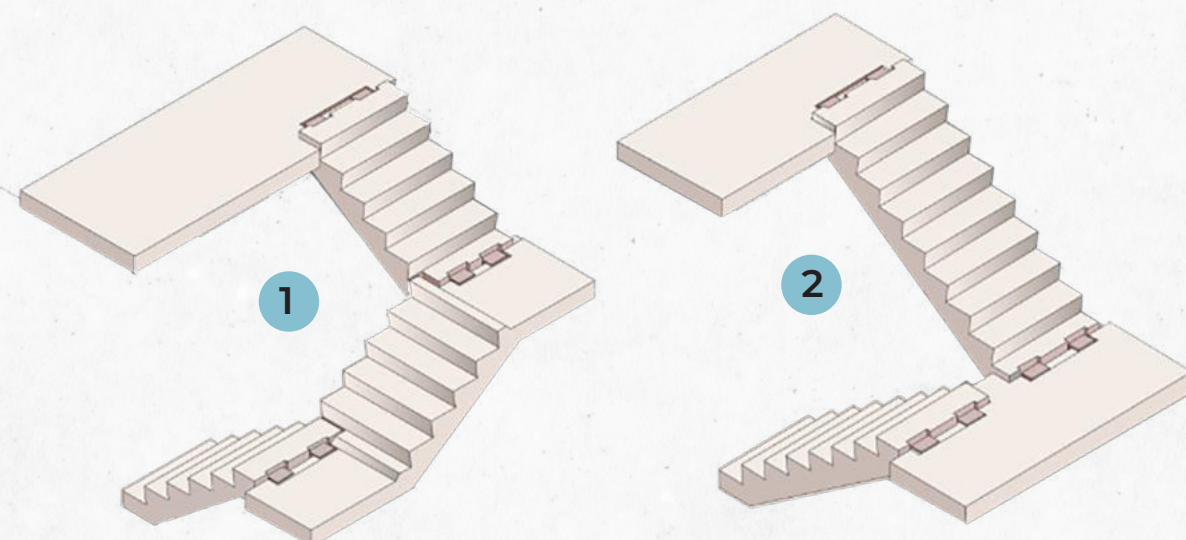



Možne dimenzije montažnega stopnišča, ki ga naredimo v svoji proizvodnji, so podane na spodnji risbi:

The possible dimensions of the prefabricated staircase that we make in our section are given in the following drawing:

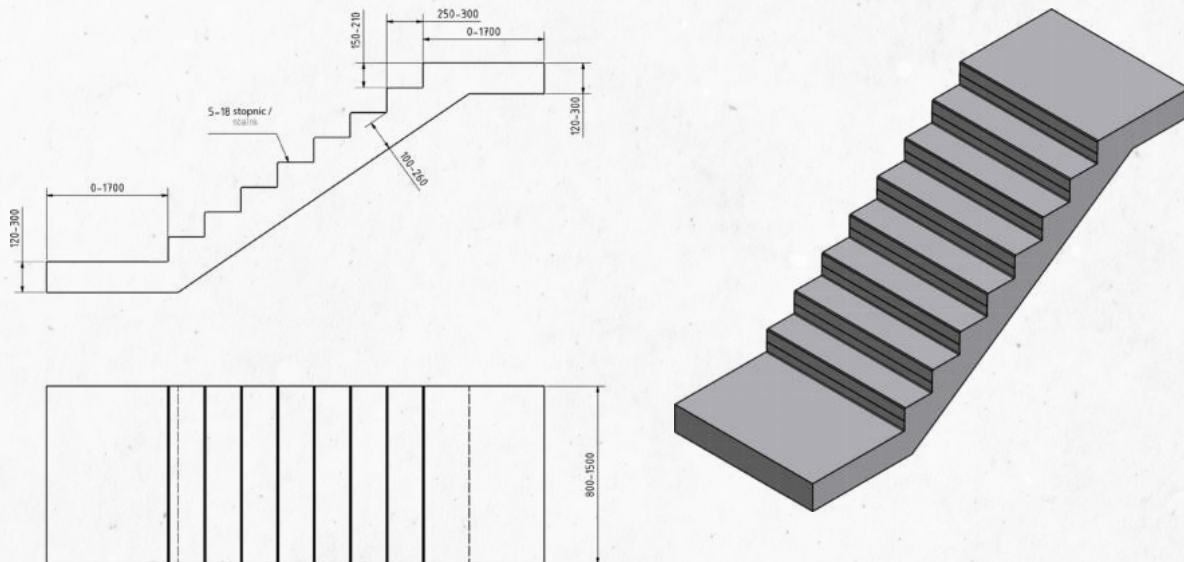

- ABOUT US
- FOUNDATION CUPS
- COLUMNS
- FLOOR BEAMS
- HOLLOW-CORE SLABS
- DOUBLE-TT SLABS
- CRANE GIRDERS
- MAIN BEAMS
- PURLINS
- MULTIPURPOSE RECTANGULAR BEAMS
- FACADE PANELS
- LOADING DOCKS
- SYSTEM FOR RESIDENTIAL BUILDING
- REF. OBJECTS

STAIRS



Lastnosti: Characteristics:

1 Hitrost in preprostost instalacije Speed and simplicity of installation

Ker so stopnice na voljo kot končani element, se prihrani čas izgradnje. Potrebno je samo, da se prinesejo in postavijo. Ko so popolnoma pritrjene, so pripravljene za uporabo.

As stairs are readily available, it saves construction time. They are to be brought and fixed. Once fixed perfectly they are ready to use.

2 Varnost Safety

Betonske stopnice omogočajo varnejši pristop različnim etažam med izgradnjo kot pa lestve ali drugi začasni sistemi.

Concrete stairs provide safer access to different floors during construction than ladders or other temporary systems.

3 Površinska obdelava Surface finish

Ker se stopnice izdelujejo v kalupu iz visokokakovostnega železa, se dobi eleganten (gladek) zaključni sloj elementa.

As these stairs are moulded in high-quality steel, the open surface is troweled to give sleek finish.

4 Koristi Attractive

Beton daje elastično, čvrsto, vzdržljivo osnovo za atraktivne zaključne obdelave, kot so les, kamen, ploščice ali kateri koli drugi zaključni premazi.

Concrete gives resilient, solid, durable base for attractive finishes like timber, stone, tiles or any other finish to be added.

5 Velikost Size

Prefabricirane stopnice je lahko narediti z različnimi širinami stopnišnega trakta. V odvisnosti od zahtev projekta so mogoča odstopanja od standardnih dimenzij (npr. manjša odstopanja).

Prefabricated stairs can be made with different widths stair tract. Depending on the requirements of the project, deviations from the standard dimensions are possible (ie, less variation).

6 Odpornost proti ognju Fire resistance

Ker so narejene iz betona, imajo prefabricirane stopnice visoko stopnjo odpornosti proti ognju.

As they are made of concrete, they resist fire. Since they are made of concrete, prefabricated stairs have a high degree of fire resistance.



Prednosti: Benefits:

- **Napredne mehanske vezi pospešujejo proces vgradnje in odpravljajo potrebo po podpiranju (začasne podpore);**
- Advanced mechanical connection, speeds the installation process along with eliminating the need of propping (temporary supports);
- **Prefabricirane stopnice so oblikovane in proizvedene glede na določeno višino tal in zahteve;**
- Precast stairs are designed and manufactured to any specific floor height and application;
- **So trajne in ne potrebujejo posebnega vzdrževanja;**
- These are durable and maintenance free;
- **Odpravljajo potrebo po začasnem stopnišču med izgradnjo;**
- Eliminates the need for temporary stairs during construction;
- **Varnostne šine in ograje se lahko vgradijo pred postavljanjem;**
- Safety rails and handrail can be pre-installed prior to installation;
- **Boljša kontrola kakovosti;**
- Better quality control;

Potrebni sta dodatna pozornost in previdnost za doseg monolitnih spojev med prefabriciranimi stopniščnimi elementi in konstrukcijskimi elementi (litih ali prav tako prefabriciranih), to pomeni, da morajo biti prefabricirane stopnice pravilno postavljene, da se lahko ujemajo z drugimi konstrukcijskimi elementi.

Additional care is required, and safety measures in order to obtain compounds of the monolithic prefabricated between the stepped element and the structural elements (also cast or pre-cast), ie. precast steps should be properly placed and matched with other structural elements.

ABOUT
US

FOUNDATION
CUPS

COLUMNS

FLOOR
BEAMS

HOLLOW-
CORE
SLABS

DOUBLE
TT
SLABS

CRANE
GIRDERS

MAIN
BEAMS

PURLINS

MULTIPURPOSE
RECTANGULAR
BEAMS

FACADE
PANELS

LOADING
DOCKS

SYSTEM FOR
RESIDENTIAL
BUILDING

STAIRS

REF.
OBJECTS



O NAS

TEMELJNE
ČAŠE

STEBRI

MEDETAŽNI
NOSILCI

VOTLE
PLOŠČE

TT
PLOŠČE

ŽERJAVNE
PROGE

GLAVNI
NOSILCI

GREDICE

VEČNAMENSKE
PRAVOKOTNE
GREDE

FASADNI
PANELI

NAKLADALNE
PLOŠČADI

SISTEM ZA
GRADNJO
STAVB

STOPNICE

REF.
OBJEKTI

Referenčni objekti

Reference objects



Logistični center LIDL, Arja vas, 57.000 m²



Kuehne & Nagel, Brnik, 33.000 m²



ATL Cargo Partner, Brnik, 22.000 m²



ABOUT US FOUNDATION CUPS COLUMNS FLOOR BEAMS HOLLOW-CORE SLABS DOUBLE-T SLABS CRANE GIRDERS MAIN BEAMS PURLINS MULTIPURPOSE RECTANGULAR BEAMS FACADE PANELS LOADING DOCKS SYSTEM FOR RESIDENTIAL BUILDING STAIRS REF. OBJECTS



LT 4, Brnik, 4.000 m²



Avtoline, Krško, 3.000 m²



Willy Stadler, Krško, 3.300 m²





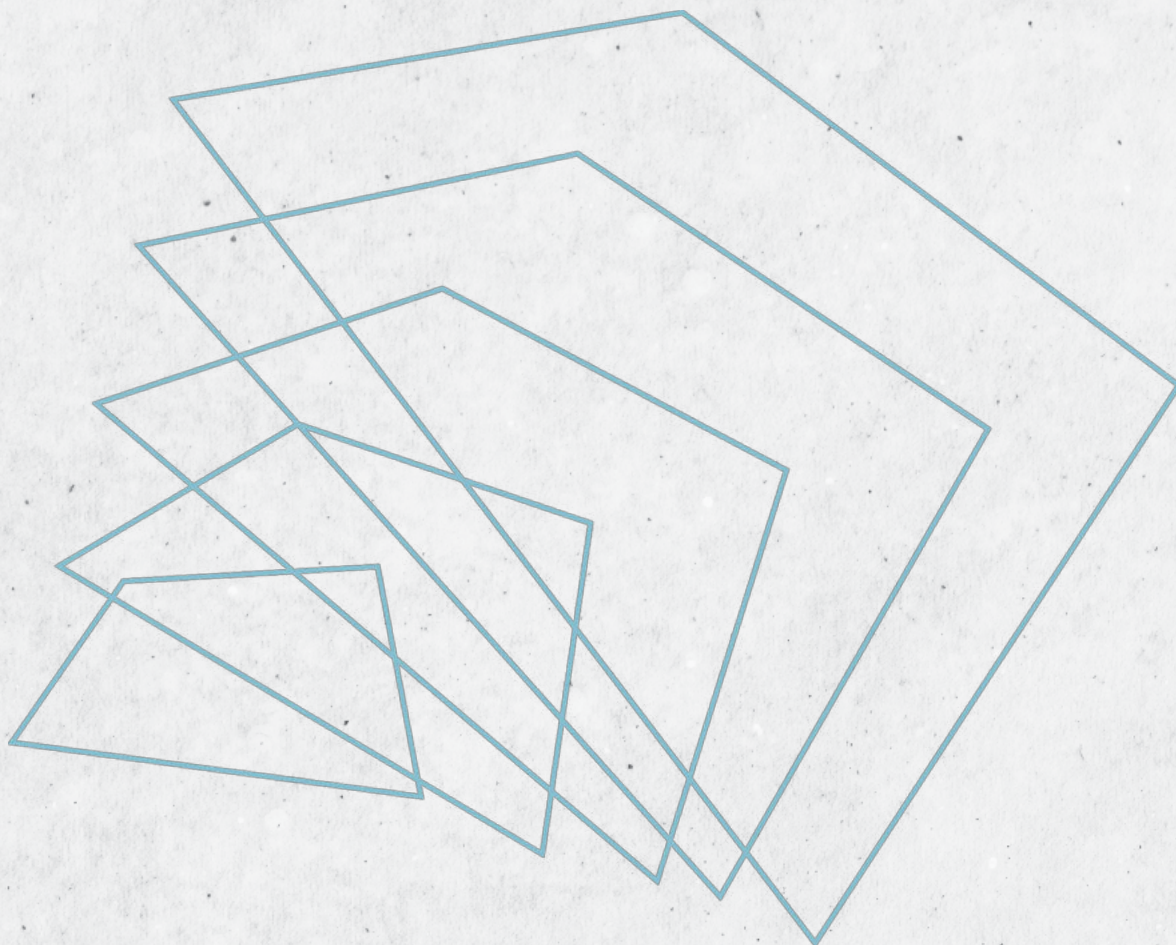

Mobeco d.o.o.
Velika vas pri Krškem 62,
SI - 8273 Leskovec pri Krškem

ID za DDV: SI59648856
Matična številka: 7297505000

+386 8 20 10 375
office@mobeco.si

www.mobeco.si